



UNITED STATES PATENT AND TRADEMARK OFFICE

UNITED STATES DEPARTMENT OF COMMERCE
United States Patent and Trademark Office
Address: COMMISSIONER FOR PATENTS
P.O. Box 1450
Alexandria, Virginia 22313-1450
www.uspto.gov

APPLICATION NO.	ISSUE DATE	PATENT NO.	ATTORNEY DOCKET NO.	CONFIRMATION NO.
29/480,113	07/15/2014	D709248	A.HAZ-003	2342

59259 7590 06/25/2014
ITALIA IP
3500 WEST OLIVE AVE.
SUITE 300
BURBANK, CA 91505

ISSUE NOTIFICATION

The projected patent number and issue date are specified above.

Determination of Patent Term Extension or Adjustment under 35 U.S.C. 154 (b)

Design patents have a term measured from the issue date of the patent and the term remains the same length regardless of the time that the application for the design patent was pending. Since the above-identified application is an application for a design patent, the patent is not eligible for Patent Term Extension or Adjustment under 35 U.S.C. 154(b).

Any questions regarding the Patent Term Extension or Adjustment determination should be directed to the Office of Patent Legal Administration at (571)-272-7702. Questions relating to issue and publication fee payments should be directed to the Application Assistance Unit (AAU) of the Office of Data Management (ODM) at (571)-272-4200.

APPLICANT(s) (Please see PAIR WEB site <http://pair.uspto.gov> for additional applicants):

Archie Hazel, Jonesboro, IL;

The United States represents the largest, most dynamic marketplace in the world and is an unparalleled location for business investment, innovation, and commercialization of new technologies. The USA offers tremendous resources and advantages for those who invest and manufacture goods here. Through SelectUSA, our nation works to encourage and facilitate business investment. To learn more about why the USA is the best country in the world to develop technology, manufacture products, and grow your business, visit SelectUSA.gov.

Notice of References Cited	Application/Control No. 29/480,113	Applicant(s)/Patent Under Reexamination HAZEL, ARCHIE	
	Examiner SUSAN M. LEE	Art Unit 2918	Page 12 of 13

U.S. PATENT DOCUMENTS

*		Document Number Country Code-Number-Kind Code	Date MM-YYYY	Name	Classification
*	A	US-2009/0308321	12-2009	Szczygiel- Durante, Lisa	119/72
*	B	US-2010/0024738	02-2010	CHEN et al.	119/72
*	C	US-2010/0224132	09-2010	Gauker et al.	119/80
*	D	US-2013/0239478	09-2013	Weder, Donald E.	47/72
*	E	US-5,771,614	06-1998	Dawson, Neil K.	40/124.06
*	F	US-4,446,178	05-1984	Daugherty, Yvonne B.	428/26
*	G	US-D698,501	01-2014	Muhr et al.	D30/124
*	H	US-D698,102	01-2014	Muhr et al.	D30/124
*	I	US-D698,101	01-2014	Muhr et al.	D30/124
*	J	US-D698,100	01-2014	Muhr et al.	D30/124
*	K	US-D698,099	01-2014	Muhr et al.	D30/124
*	L	US-D698,098	01-2014	Muhr et al.	D30/124
*	M	US-D211,887	08-1968	Name not available Dearling	D6/539

Change(s) applied

to document,
*
MXH/
4/18/2014

FOREIGN PATENT DOCUMENTS

*		Document Number Country Code-Number-Kind Code	Date MM-YYYY	Country	Name	Classification
	N					
	O					
	P					
	Q					
	R					
	S					
	T					

NON-PATENT DOCUMENTS

*		Include as applicable: Author, Title Date, Publisher, Edition or Volume, Pertinent Pages)
	U	
	V	
	W	
	X	

*A copy of this reference is not being furnished with this Office action. (See MPEP § 707.05(a).)
Dates in MM-YYYY format are publication dates. Classifications may be US or foreign.

SCORE Placeholder Sheet for IFW Content

Application Number: 29480113

Document Date: 05/27/2014

The presence of this form in the IFW record indicates that the following document type was received in electronic format on the date identified above. This content is stored in the SCORE database.

Since this was an electronic submission, there is no physical artifact folder, no artifact folder is recorded in PALM, and no paper documents or physical media exist. The TIFF images in the IFW record were created from the original documents that are stored in SCORE.

- Drawing

At the time of document entry (noted above):

- USPTO employees may access SCORE content via eDAN using the Supplemental Content tab, or via the SCORE web page.
- External customers may access SCORE content via PAIR using the Supplemental Content tab.

PART B - FEE(S) TRANSMITTAL

Complete and send this form, together with applicable fee(s), to: **Mail** Mail Stop ISSUE FEE
Commissioner for Patents
P.O. Box 1450
Alexandria, Virginia 22313-1450
 or **Fax** (571)-273-2885

INSTRUCTIONS: This form should be used for transmitting the ISSUE FEE and PUBLICATION FEE (if required). Blocks 1 through 5 should be completed where appropriate. All further correspondence including the Patent, advance orders and notification of maintenance fees will be mailed to the current correspondence address as indicated unless corrected below or directed otherwise in Block 1, by (a) specifying a new correspondence address; and/or (b) indicating a separate "FEE ADDRESS" for maintenance fee notifications.

Note: A certificate of mailing can only be used for domestic mailings of the Fee(s) Transmittal. This certificate cannot be used for any other accompanying papers. Each additional paper, such as an assignment or formal drawing, must have its own certificate of mailing or transmission.

CURRENT CORRESPONDENCE ADDRESS (Note: Use Block 1 for any change of address):

Certificate of Mailing or Transmission

I hereby certify that this Fee(s) Transmittal is being deposited with the United States Postal Service with sufficient postage for first class mail in an envelope addressed to the Mail Stop ISSUE FEE address above, or being facsimile transmitted to the USPTO (571) 273-2885, on the date indicated below.

59259 7590 04/09/2014
ITALIA IP
3500 WEST OLIVE AVE.
SUITE 300
BURBANK, CA 91505

Via	(Depositor's name)
EPS-Web	(Signature)
	(Date)

APPLICATION NO.	FILING DATE	FIRST NAMED INVENTOR	ATTORNEY DOCKET NO.	CONFIRMATION NO.
29/480,113	01/23/2014	Archie Hazel	A.HAZ-003	2342

TITLE OF INVENTION: HUMMINGBIRD FEEDER PARTITION

APPLN. TYPE	ENTITY STATUS	ISSUE FEE DUE	PUBLICATION FEE DUE	PREV. PAID ISSUE FEE	TOTAL FEE(S) DUE	DATE DUE
nonprovisional	MICRO	\$140	\$0	\$0	\$140	07/09/2014

EXAMINER	ART UNIT	CLASS-SUBCLASS
LEE, SUSAN M	2918	D30-124000

1. Change of correspondence address or indication of "Fee Address" (37 CFR 1.363).

Change of correspondence address (or Change of Correspondence Address form PTO/SB/122) attached.

"Fee Address" indication (or "Fee Address" Indication form PTO/SB/17; Rev 03-02 or more recent) attached. **Use of a Customer Number is required.**

2. For printing on the patent front page, list

(1) The names of up to 3 registered patent attorneys or agents; OR, alternatively,

(2) The name of a single firm (having as a member a registered attorney or agent) and the names of up to 2 registered patent attorneys or agents. If no name is listed, no name will be printed.

1. James A. Italia

2. _____

3. _____

3. ASSIGNEE NAME AND RESIDENCE DATA TO BE PRINTED ON THE PATENT (print or type)

PLEASE NOTE: Unless an assignee is identified below, no assignee data will appear on the patent. If an assignee is identified below, the document has been filed for recordation as set forth in 37 CFR 3.11. Completion of this form is NOT a substitute for filing an assignment.

(A) NAME OF ASSIGNEE _____ (B) RESIDENCE: (CITY and STATE OR COUNTRY) _____

Please check the appropriate assignee category or categories (will not be printed on the patent): Individual Corporation or other private group entity Government

4a. The following fee(s) are submitted:

Issue Fee

Publication Fee (No small entity discount permitted)

Advance Order - # of Copies _____

4b. Payment of Fee(s): (Please first reapply any previously paid issue fee shown above)

A check is enclosed.

Payment by credit card. ~~Form PTO-2013 is attached~~ Via EPS-Web

The Director is hereby authorized to charge the required fee(s), any deficiency, or credits any overpayment, to Deposit Account Number _____ (enclose an extra copy of this form).

5. Change in Entity Status (from status indicated above)

Applicant certifying micro entity status. See 37 CFR 1.29

Applicant asserting small entity status. See 37 CFR 1.27

Applicant changing to regular undiscouted fee status

NOTE: Absent a valid certification of Micro Entity Status (see forms PTO/SB/15A and 15B), issue fee payment in the micro entity amount will not be accepted at the risk of application abandonment.

NOTE: If the application was previously under micro entity status, checking this box will be taken to be a notification of loss of entitlement to micro entity status.

NOTE: Checking this box will be taken to be a notification of loss of entitlement to small or micro entity status, as applicable.

NOTE: This form must be signed in accordance with 37 CFR 1.31 and 1.33. See 37 CFR 1.4 for signature requirements and certifications.

Authorized Signature _____ Date 5/27/14

Typed or printed name James A. Italia Registration No 56,549

IN THE UNITED STATES PATENT AND TRADEMARK OFFICE

In Re: Patent Application of:
Archie Hazel

Serial No. 29/480,113

Confirmation No. 2342

Filed: January 23, 2014

For: HUMMINGBIRD FEEDER
PARTITION

Group Art Unit: 2918

Examiner: Susan M. Lee

Burbank, California
May 27, 2014

RESPONSE TO NOTICE OF ALLOWANCE

Hon. Commissioner of Patents:

A Notice of Allowance was issued in the above-identified application on April 9, 2014.

Attached are Replacement Sheets in response to the Notice of Allowance. We believe the application is now in condition of allowance.

Respectfully submitted,

ITALIA IP
Attorneys for Applicant

By: /James A. Italia/
James A. Italia
Registration Number 56,549

REPLACEMENT SHEET

1/5

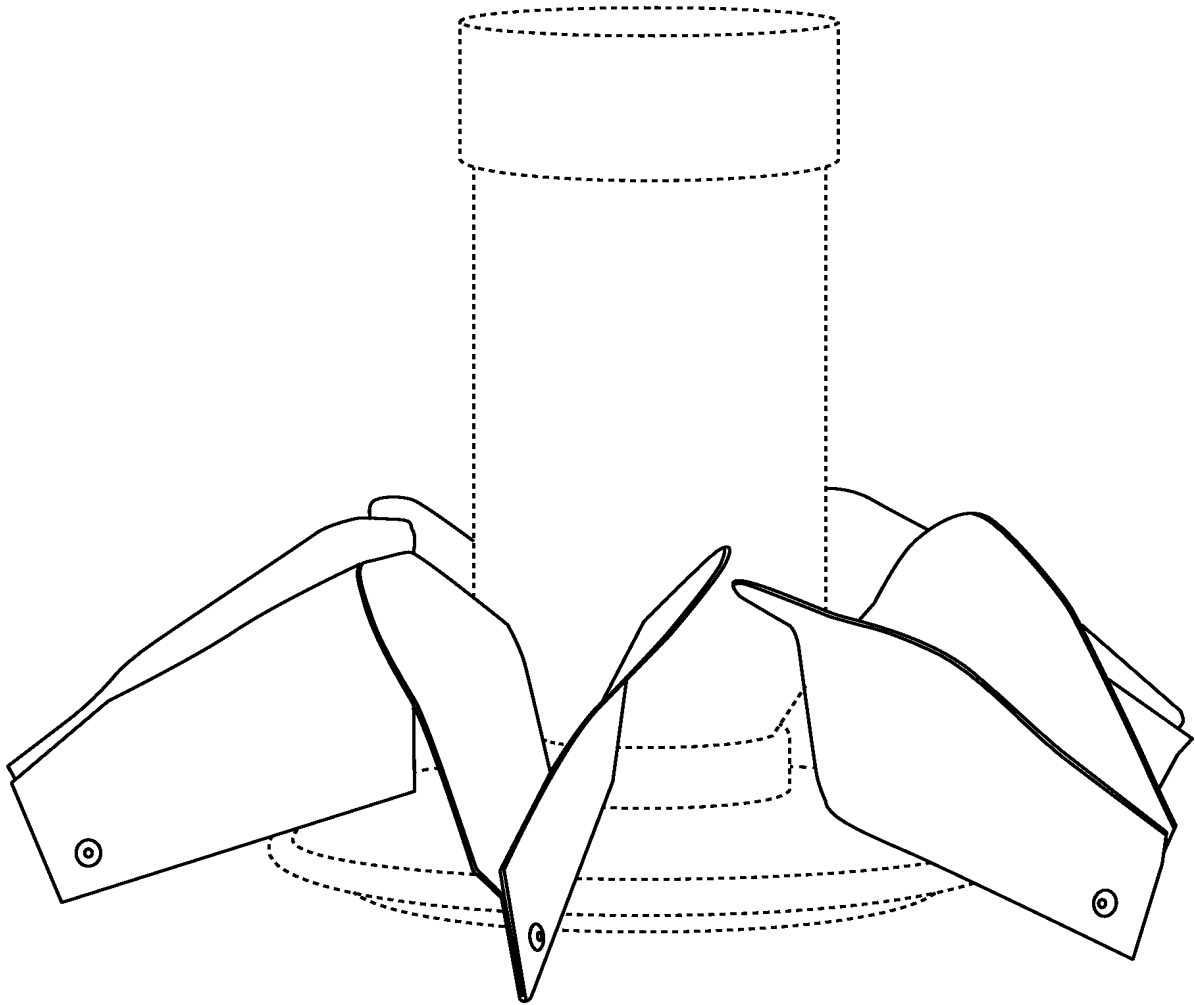

FIG. 1

REPLACEMENT SHEET

2/5

FIG. 2

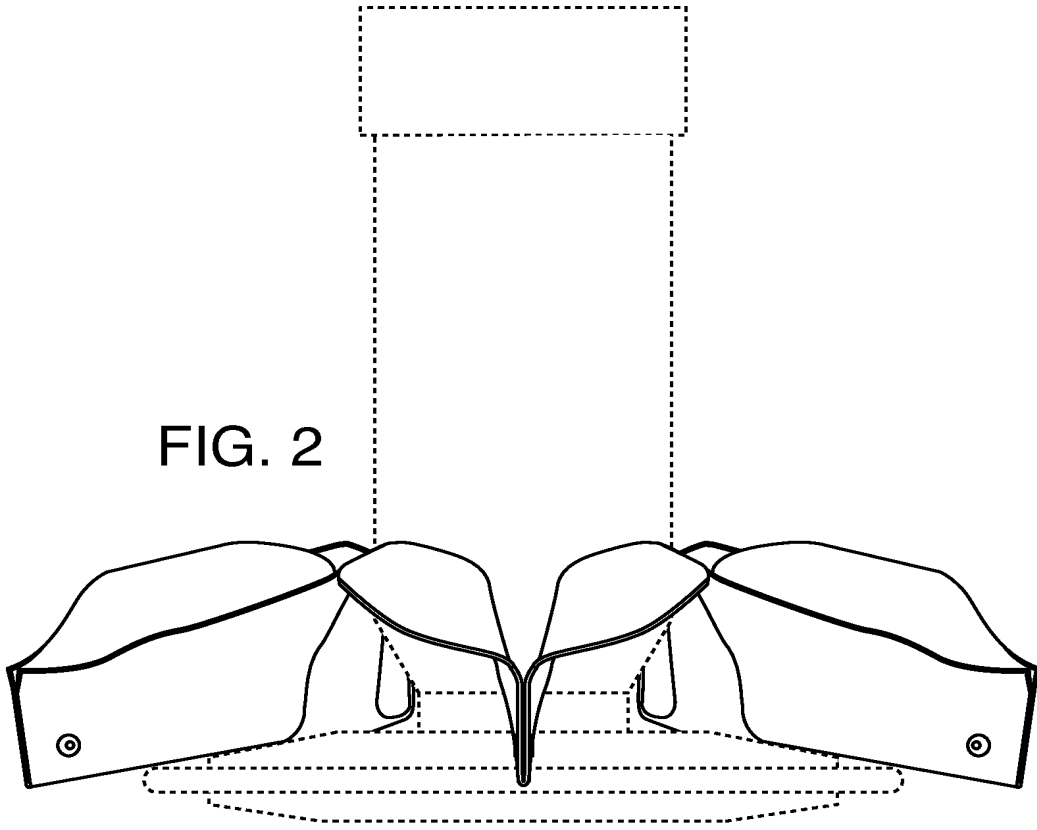
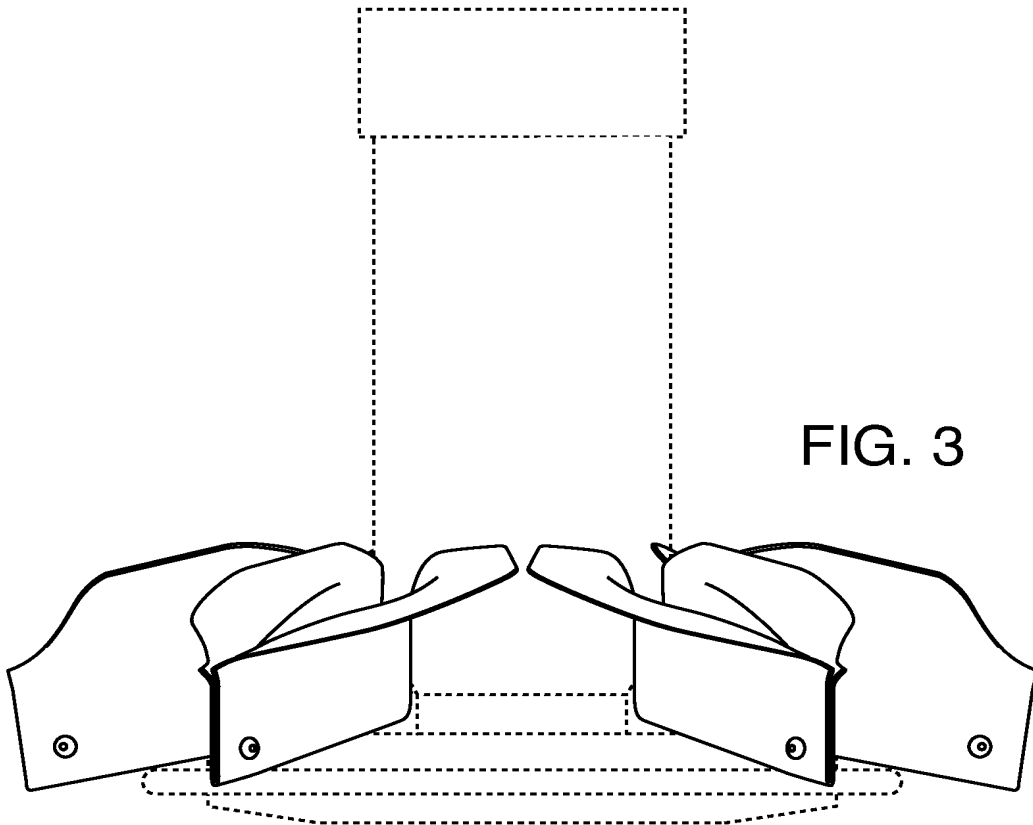

FIG. 3



REPLACEMENT SHEET

3/5

FIG. 4

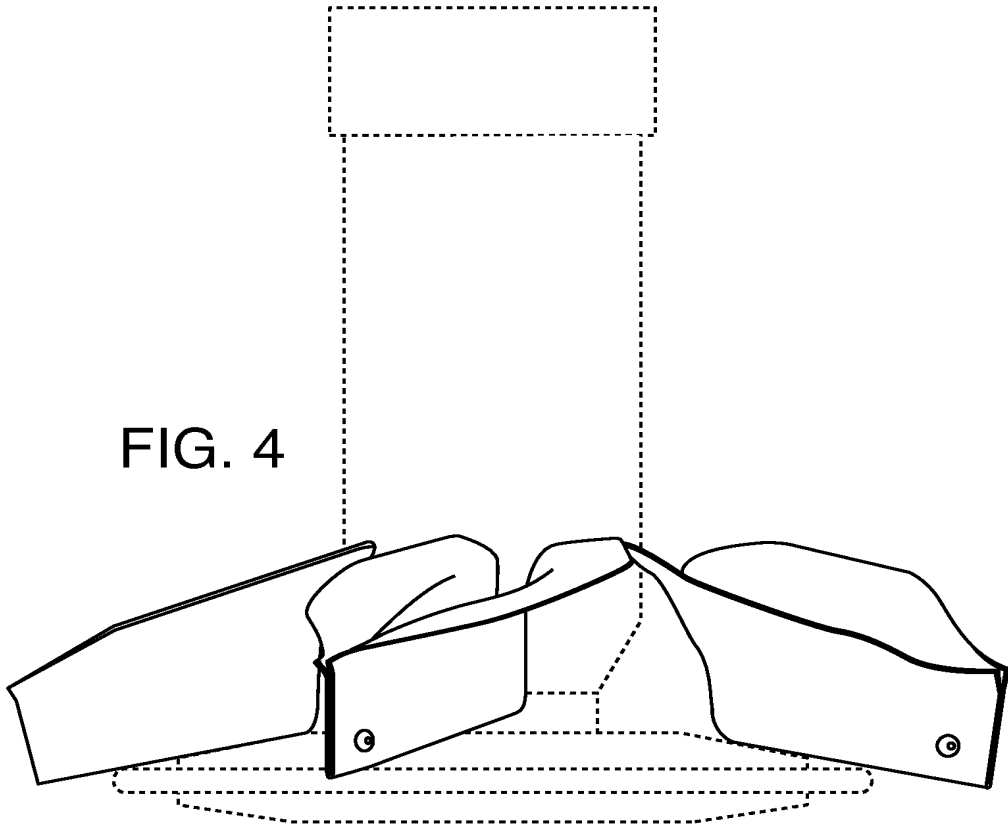
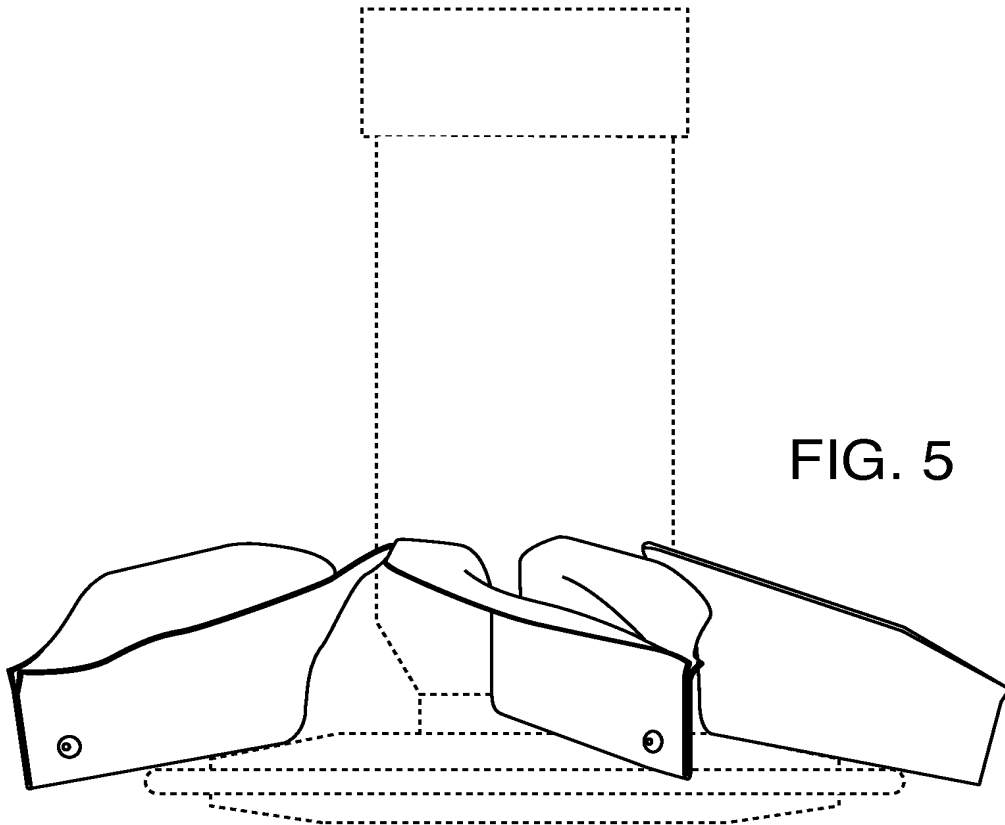

FIG. 5



REPLACEMENT SHEET

4/5

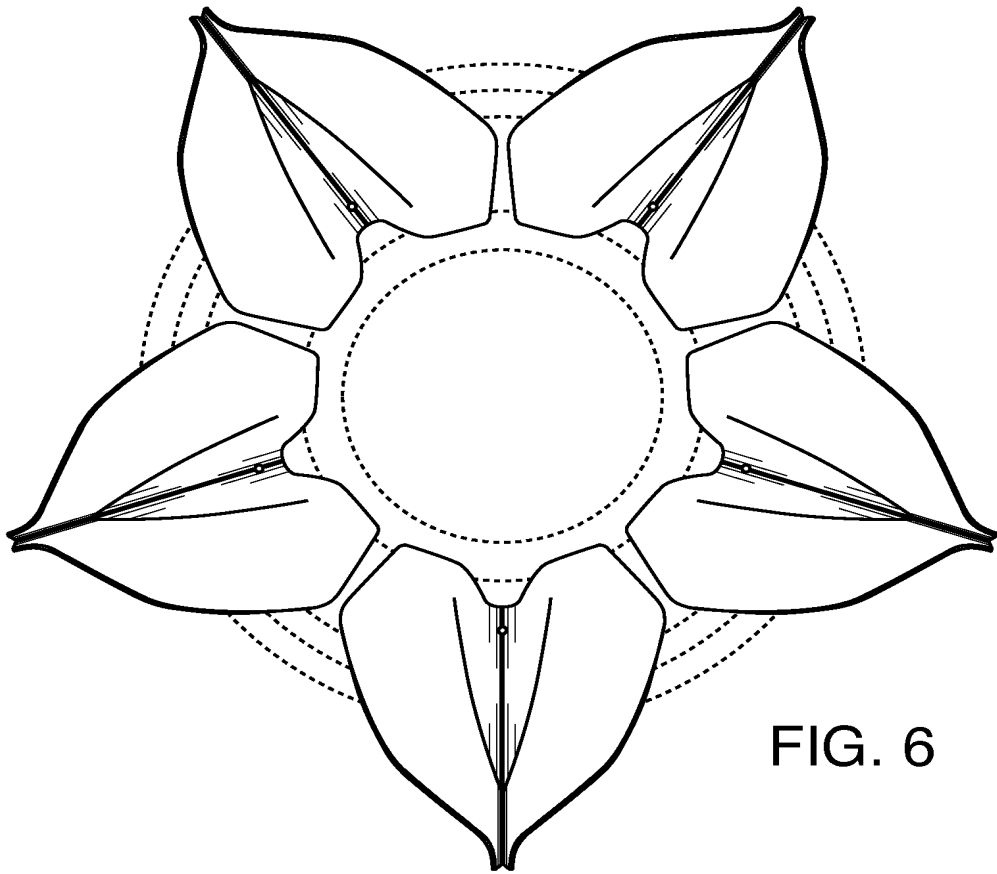

FIG. 6

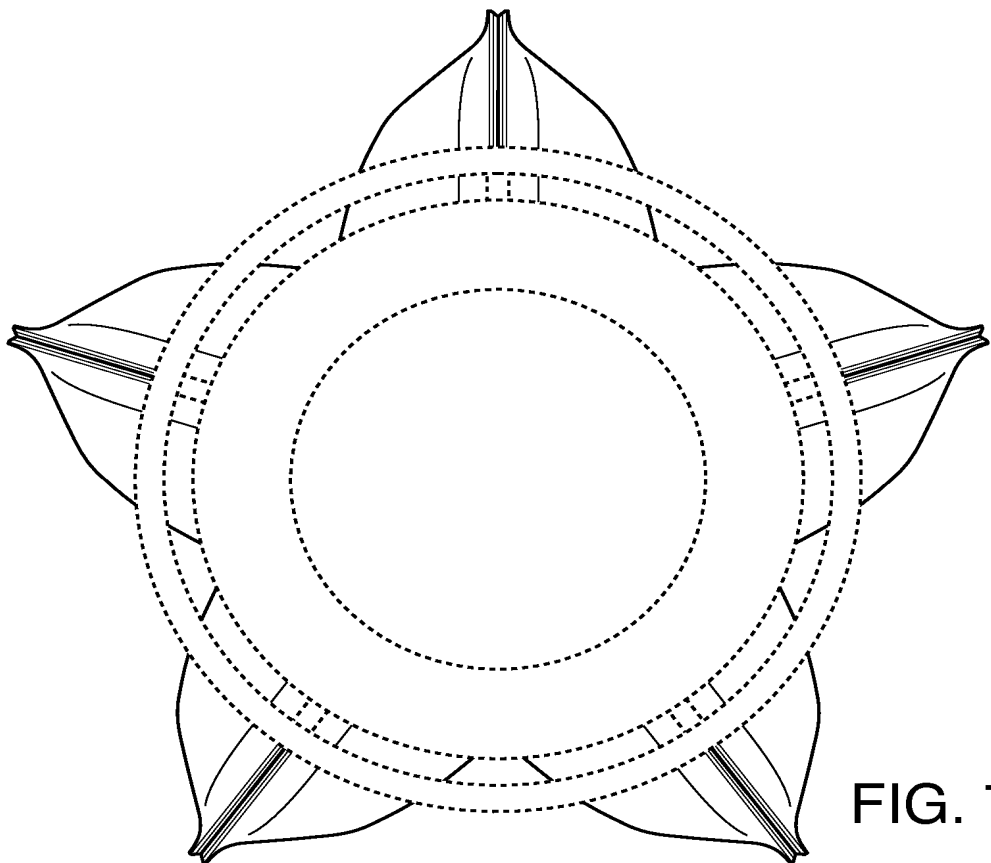

FIG. 7

REPLACEMENT SHEET

5/5

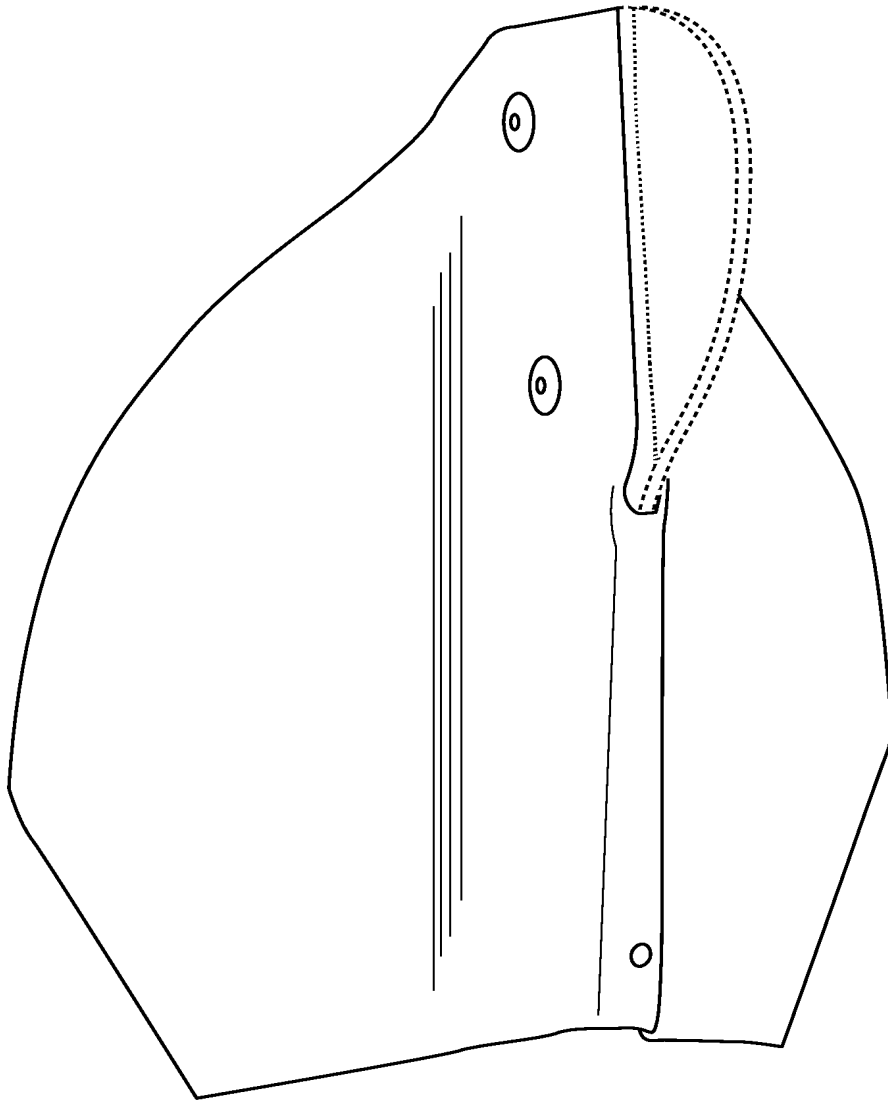

FIG. 8

Electronic Patent Application Fee Transmittal

Application Number:	29480113
Filing Date:	23-Jan-2014
Title of Invention:	HUMMINGBIRD FEEDER PARTITION
First Named Inventor/Applicant Name:	Archie Hazel
Filer:	James Anthony Italia
Attorney Docket Number:	A.HAZ-003

Filed as Micro Entity

Design Filing Fees

Description	Fee Code	Quantity	Amount	Sub-Total in USD(\$)
Basic Filing:				
Pages:				
Claims:				
Miscellaneous-Filing:				
Petition:				
Patent-Appeals-and-Interference:				
Post-Allowance-and-Post-Issuance:				
Design Issue Fee	3502	1	140	140
Publ. Fee- Early, Voluntary, or Normal	1504	1	0	0

Description	Fee Code	Quantity	Amount	Sub-Total in USD(\$)
Extension-of-Time:				
Miscellaneous:				
Total in USD (\$)				140

Electronic Acknowledgement Receipt

EFS ID:	19136942
Application Number:	29480113
International Application Number:	
Confirmation Number:	2342
Title of Invention:	HUMMINGBIRD FEEDER PARTITION
First Named Inventor/Applicant Name:	Archie Hazel
Customer Number:	59259
Filer:	James Anthony Italia
Filer Authorized By:	
Attorney Docket Number:	A.HAZ-003
Receipt Date:	27-MAY-2014
Filing Date:	23-JAN-2014
Time Stamp:	17:37:35
Application Type:	Design

Payment information:

Submitted with Payment	yes
Payment Type	Credit Card
Payment was successfully received in RAM	\$140
RAM confirmation Number	5494
Deposit Account	
Authorized User	

File Listing:

Document Number	Document Description	File Name	File Size(Bytes)/ Message Digest	Multi Part /.zip	Pages (if appl.)
-----------------	----------------------	-----------	----------------------------------	------------------	------------------

1	Issue Fee Payment (PTO-85B)	IssueFee.pdf	889776 74f5a92c6003bb447201fdd88bb1772794c3db25	no	1
Warnings:					
Information:					
2	Miscellaneous Incoming Letter	NOAResponse.pdf	12371 660b99876dd8659dff122eda8de4ff34d80e1b4	no	1
Warnings:					
Information:					
3	Drawings-only black and white line drawings	ReplacementSheet.pdf	169754 d3bde483ca5874b7c1ccfeb6bc013997ab0cb89	no	5
Warnings:					
Information:					
4	Fee Worksheet (SB06)	fee-info.pdf	31359 69fc8376d3807f6c66dc8c0b58785475e49f6f10	no	2
Warnings:					
Information:					
Total Files Size (in bytes):				1103260	

This Acknowledgement Receipt evidences receipt on the noted date by the USPTO of the indicated documents, characterized by the applicant, and including page counts, where applicable. It serves as evidence of receipt similar to a Post Card, as described in MPEP 503.

New Applications Under 35 U.S.C. 111

If a new application is being filed and the application includes the necessary components for a filing date (see 37 CFR 1.53(b)-(d) and MPEP 506), a Filing Receipt (37 CFR 1.54) will be issued in due course and the date shown on this Acknowledgement Receipt will establish the filing date of the application.

National Stage of an International Application under 35 U.S.C. 371

If a timely submission to enter the national stage of an international application is compliant with the conditions of 35 U.S.C. 371 and other applicable requirements a Form PCT/DO/EO/903 indicating acceptance of the application as a national stage submission under 35 U.S.C. 371 will be issued in addition to the Filing Receipt, in due course.

New International Application Filed with the USPTO as a Receiving Office

If a new international application is being filed and the international application includes the necessary components for an international filing date (see PCT Article 11 and MPEP 1810), a Notification of the International Application Number and of the International Filing Date (Form PCT/RO/105) will be issued in due course, subject to prescriptions concerning national security, and the date shown on this Acknowledgement Receipt will establish the international filing date of the application.

PART B - FEE(S) TRANSMITTAL

Complete and send this form, together with applicable fee(s), to: **Mail** Mail Stop ISSUE FEE
 Commissioner for Patents
 P.O. Box 1450
 Alexandria, Virginia 22313-1450
 or **Fax** (571)-273-2885

DM

INSTRUCTIONS: This form should be used for transmitting the ISSUE FEE and PUBLICATION FEE (if required). Blocks 1 through 5 should be completed where appropriate. All further correspondence including the Patent, advance orders and notification of maintenance fees will be mailed to the current correspondence address as indicated unless corrected below or directed otherwise in Block 1, by (a) specifying a new correspondence address; and/or (b) indicating a separate "FEE ADDRESS" for maintenance fee notifications.

CURRENT CORRESPONDENCE ADDRESS (Note: Use Block 1 for any change of address):

59259 75091 04/19/2014
 ITALIA IP
 3500 WEST OLIVE AVE.
 SUITE 300
 BURBANK, CA 91505



Note: A certificate of mailing can only be used for domestic mailings of the Fee(s) Transmittal. This certificate cannot be used for any other accompanying papers. Each additional paper, such as an assignment or formal drawing, must have its own certificate of mailing or transmission.

Certificate of Mailing or Transmission

I hereby certify that this Fee(s) Transmittal is being deposited with the United States Postal Service with sufficient postage for first-class mail in an envelope addressed to the Mail Stop ISSUE FEE address above, or being facsimile transmitted to the USPTO (571) 273-2885, on the date indicated below.

Via	(Depositor's name)
EFS-Web	(Signature)
	(Date)

APPLICATION NO.	FILING DATE	FIRST NAMED INVENTOR	ATTORNEY DOCKET NO.	CONFIRMATION NO.
29/480,113	01/23/2014	Archie Hazel	A.HAZ-003	2342

TITLE OF INVENTION: HUMMINGBIRD FEEDER PARTITION

APPL. TYPE	ENTITY STATUS	ISSUE FEE DUE	PUBLICATION FEE DUE	PREV. PAID ISSUE FEE	TOTAL FEE(S) DUE	DATE DUE
nonprovisional	MICRO	\$140	\$0	\$0	\$140	07/09/2014

EXAMINER	ART UNIT	CLASS-SUBCLASS
LEE, SUSAN M	2918	D30-124000

1. Change of correspondence address or indication of "Fee Address" (37 CFR 1.363).
 Change of correspondence address (or Change of Correspondence Address form PTO/SB/122) attached.
 "Fee Address" indication (or "Fee Address" Indication form PTO/SB/17; Rev. 03-02 or more recent) attached. Use of a Customer Number is required.

2. For printing on the patent front page, list:
 (1) The names of up to 3 registered patent attorneys or agents; OR, alternatively,
 (2) The name of a single firm (having as a member a registered attorney or agent) and the names of up to 2 registered patent attorneys or agents. If no name is listed, no name will be printed.

1. James A. Italia
 2. _____
 3. _____

3. ASSIGNEE NAME AND RESIDENCE DATA TO BE PRINTED ON THE PATENT (print or type)
 PLEASE NOTE: Unless an assignee is identified below, no assignee data will appear on the patent. If an assignee is identified below, the document has been filed for recordation as set forth in 37 CFR 3.11. Completion of this form is NOT a substitute for filing an assignment.
 (A) NAME OF ASSIGNEE: _____ (B) RESIDENCE: (CITY and STATE OR COUNTRY) _____

Please check the appropriate assignee category or categories (will not be printed on the patent): Individual Corporation or other private group entity Government

4a. The following fee(s) are submitted:
 Issue Fee
 Publication Fee (No small entity discount permitted)
 Advance Order - # of Copies _____

4b. Payment of Fee(s): (Please first reapply any previously paid issue fee shown above)
 A check is enclosed.
 Payment by credit card. Form PTO-2038 is attached. Via EFS-Web
 The Director is hereby authorized to charge the required fee(s), any deficiency, or credits any overpayment, to Deposit Account Number _____ (enclose an extra copy of this form).

5. Change in Entity Status (from status indicated above)
 Applicant certifying micro entity status. See 37 CFR 1.29
 Applicant asserting small entity status. See 37 CFR 1.27
 Applicant changing to regular undiscounted fee status.

NOTE: Absent a valid certification of Micro Entity Status (see forms PTO/SB/15A and 15B), issue fee payment in the micro entity amount will not be accepted at the risk of application abandonment.
 NOTE: If the application was previously under micro entity status, checking this box will be taken to be a notification of loss of entitlement to micro entity status.
 NOTE: Checking this box will be taken to be a notification of loss of entitlement to small or micro entity status, as applicable.

NOTE: This form must be signed in accordance with 37 CFR 1.33 and 1.33. See 37 CFR 1.4 for signature requirements and certifications.

Authorized Signature: James A. Italia Date: 5/27/14
 Typed or printed name: James A. Italia Registration No. 56,549



PATENT
A.HAZ-003

IN THE UNITED STATES PATENT AND TRADEMARK OFFICE

In Re: Patent Application of:
Archie Hazel

Serial No. 29/480,113

Confirmation No. 2342

Filed: January 23, 2014

For: HUMMINGBIRD FEEDER
PARTITION

Group Art Unit: 2918

Examiner: Susan M. Lee

Burbank, California
May 27, 2014

RESPONSE TO NOTICE OF ALLOWANCE

Hon. Commissioner of Patents:

A Notice of Allowance was issued in the above-identified application on April 9, 2014.

Attached are Replacement Sheets in response to the Notice of Allowance. We believe the application is now in condition of allowance.

Respectfully submitted,

ITALIA IP
Attorneys for Applicant

By: /James A. Italia/
James A. Italia
Registration Number 56,549



NOTICE OF ALLOWANCE AND FEE(S) DUE

59259 7590 04/09/2014
ITALIA IP
3500 WEST OLIVE AVE.
SUITE 300
BURBANK, CA 91505

Table with 2 columns: EXAMINER (LEE, SUSAN M), ART UNIT (2918), PAPER NUMBER

DATE MAILED: 04/09/2014

Table with 5 columns: APPLICATION NO., FILING DATE, FIRST NAMED INVENTOR, ATTORNEY DOCKET NO., CONFIRMATION NO.

TITLE OF INVENTION: HUMMINGBIRD FEEDER PARTITION

Table with 7 columns: APPLN. TYPE, ENTITY STATUS, ISSUE FEE DUE, PUBLICATION FEE DUE, PREV. PAID ISSUE FEE, TOTAL FEE(S) DUE, DATE DUE

THE APPLICATION IDENTIFIED ABOVE HAS BEEN EXAMINED AND IS ALLOWED FOR ISSUANCE AS A PATENT. PROSECUTION ON THE MERITS IS CLOSED. THIS NOTICE OF ALLOWANCE IS NOT A GRANT OF PATENT RIGHTS. THIS APPLICATION IS SUBJECT TO WITHDRAWAL FROM ISSUE AT THE INITIATIVE OF THE OFFICE OR UPON PETITION BY THE APPLICANT. SEE 37 CFR 1.313 AND MPEP 1308.

THE ISSUE FEE AND PUBLICATION FEE (IF REQUIRED) MUST BE PAID WITHIN THREE MONTHS FROM THE MAILING DATE OF THIS NOTICE OR THIS APPLICATION SHALL BE REGARDED AS ABANDONED. THIS STATUTORY PERIOD CANNOT BE EXTENDED. SEE 35 U.S.C. 151. THE ISSUE FEE DUE INDICATED ABOVE DOES NOT REFLECT A CREDIT FOR ANY PREVIOUSLY PAID ISSUE FEE IN THIS APPLICATION. IF AN ISSUE FEE HAS PREVIOUSLY BEEN PAID IN THIS APPLICATION (AS SHOWN ABOVE), THE RETURN OF PART B OF THIS FORM WILL BE CONSIDERED A REQUEST TO REAPPLY THE PREVIOUSLY PAID ISSUE FEE TOWARD THE ISSUE FEE NOW DUE.

HOW TO REPLY TO THIS NOTICE:

I. Review the ENTITY STATUS shown above. If the ENTITY STATUS is shown as SMALL or MICRO, verify whether entitlement to that entity status still applies.

If the ENTITY STATUS is the same as shown above, pay the TOTAL FEE(S) DUE shown above.

If the ENTITY STATUS is changed from that shown above, on PART B - FEE(S) TRANSMITTAL, complete section number 5 titled "Change in Entity Status (from status indicated above)".

For purposes of this notice, small entity fees are 1/2 the amount of undiscounted fees, and micro entity fees are 1/2 the amount of small entity fees.

II. PART B - FEE(S) TRANSMITTAL, or its equivalent, must be completed and returned to the United States Patent and Trademark Office (USPTO) with your ISSUE FEE and PUBLICATION FEE (if required). If you are charging the fee(s) to your deposit account, section "4b" of Part B - Fee(s) Transmittal should be completed and an extra copy of the form should be submitted. If an equivalent of Part B is filed, a request to reapply a previously paid issue fee must be clearly made, and delays in processing may occur due to the difficulty in recognizing the paper as an equivalent of Part B.

III. All communications regarding this application must give the application number. Please direct all communications prior to issuance to Mail Stop ISSUE FEE unless advised to the contrary.

IMPORTANT REMINDER: Utility patents issuing on applications filed on or after Dec. 12, 1980 may require payment of maintenance fees. It is patentee's responsibility to ensure timely payment of maintenance fees when due.

PART B - FEE(S) TRANSMITTAL

**Complete and send this form, together with applicable fee(s), to: Mail Mail Stop ISSUE FEE
 Commissioner for Patents
 P.O. Box 1450
 Alexandria, Virginia 22313-1450
 or Fax (571)-273-2885**

INSTRUCTIONS: This form should be used for transmitting the ISSUE FEE and PUBLICATION FEE (if required). Blocks 1 through 5 should be completed where appropriate. All further correspondence including the Patent, advance orders and notification of maintenance fees will be mailed to the current correspondence address as indicated unless corrected below or directed otherwise in Block 1, by (a) specifying a new correspondence address; and/or (b) indicating a separate "FEE ADDRESS" for maintenance fee notifications.

Note: A certificate of mailing can only be used for domestic mailings of the Fee(s) Transmittal. This certificate cannot be used for any other accompanying papers. Each additional paper, such as an assignment or formal drawing, must have its own certificate of mailing or transmission.

CURRENT CORRESPONDENCE ADDRESS (Note: Use Block 1 for any change of address)

59259 7590 04/09/2014
ITALIA IP
 3500 WEST OLIVE AVE.
 SUITE 300
 BURBANK, CA 91505

Certificate of Mailing or Transmission

I hereby certify that this Fee(s) Transmittal is being deposited with the United States Postal Service with sufficient postage for first class mail in an envelope addressed to the Mail Stop ISSUE FEE address above, or being facsimile transmitted to the USPTO (571) 273-2885, on the date indicated below.

(Depositor's name)
(Signature)
(Date)

APPLICATION NO.	FILING DATE	FIRST NAMED INVENTOR	ATTORNEY DOCKET NO.	CONFIRMATION NO.
29/480,113	01/23/2014	Archie Hazel	A.HAZ-003	2342

TITLE OF INVENTION: HUMMINGBIRD FEEDER PARTITION

APPLN. TYPE	ENTITY STATUS	ISSUE FEE DUE	PUBLICATION FEE DUE	PREV. PAID ISSUE FEE	TOTAL FEE(S) DUE	DATE DUE
nonprovisional	MICRO	\$140	\$0	\$0	\$140	07/09/2014

EXAMINER	ART UNIT	CLASS-SUBCLASS
LEE, SUSAN M	2918	D30-124000

<p>1. Change of correspondence address or indication of "Fee Address" (37 CFR 1.363).</p> <p><input type="checkbox"/> Change of correspondence address (or Change of Correspondence Address form PTO/SB/122) attached.</p> <p><input type="checkbox"/> "Fee Address" indication (or "Fee Address" Indication form PTO/SB/47; Rev 03-02 or more recent) attached. Use of a Customer Number is required.</p>	<p>2. For printing on the patent front page, list</p> <p>(1) The names of up to 3 registered patent attorneys or agents OR, alternatively, _____ 1</p> <p>(2) The name of a single firm (having as a member a registered attorney or agent) and the names of up to 2 registered patent attorneys or agents. If no name is listed, no name will be printed. _____ 2</p> <p>_____ 3</p>
---	---

3. ASSIGNEE NAME AND RESIDENCE DATA TO BE PRINTED ON THE PATENT (print or type)

PLEASE NOTE: Unless an assignee is identified below, no assignee data will appear on the patent. If an assignee is identified below, the document has been filed for recordation as set forth in 37 CFR 3.11. Completion of this form is NOT a substitute for filing an assignment.

(A) NAME OF ASSIGNEE _____ (B) RESIDENCE: (CITY and STATE OR COUNTRY) _____

Please check the appropriate assignee category or categories (will not be printed on the patent) : Individual Corporation or other private group entity Government

<p>4a. The following fee(s) are submitted:</p> <p><input type="checkbox"/> Issue Fee</p> <p><input type="checkbox"/> Publication Fee (No small entity discount permitted)</p> <p><input type="checkbox"/> Advance Order - # of Copies _____</p>	<p>4b. Payment of Fee(s): (Please first reapply any previously paid issue fee shown above)</p> <p><input type="checkbox"/> A check is enclosed.</p> <p><input type="checkbox"/> Payment by credit card. Form PTO-2038 is attached.</p> <p><input type="checkbox"/> The Director is hereby authorized to charge the required fee(s), any deficiency, or credits any overpayment, to Deposit Account Number _____ (enclose an extra copy of this form).</p>
---	--

5. Change in Entity Status (from status indicated above)

Applicant certifying micro entity status. See 37 CFR 1.29

Applicant asserting small entity status. See 37 CFR 1.27

Applicant changing to regular undiscounted fee status.

NOTE: Absent a valid certification of Micro Entity Status (see forms PTO/SB/15A and 15B), issue fee payment in the micro entity amount will not be accepted at the risk of application abandonment.

NOTE: If the application was previously under micro entity status, checking this box will be taken to be a notification of loss of entitlement to micro entity status.

NOTE: Checking this box will be taken to be a notification of loss of entitlement to small or micro entity status, as applicable.

NOTE: This form must be signed in accordance with 37 CFR 1.31 and 1.33. See 37 CFR 1.4 for signature requirements and certifications.

Authorized Signature _____ Date _____

Typed or printed name _____ Registration No. _____



UNITED STATES PATENT AND TRADEMARK OFFICE

UNITED STATES DEPARTMENT OF COMMERCE
United States Patent and Trademark Office
Address: COMMISSIONER FOR PATENTS
P.O. Box 1450
Alexandria, Virginia 22313-1450
www.uspto.gov

Table with 5 columns: APPLICATION NO., FILING DATE, FIRST NAMED INVENTOR, ATTORNEY DOCKET NO., CONFIRMATION NO.
29/480,113 01/23/2014 Archie Hazel A.HAZ-003 2342

59259 7590 04/09/2014
ITALIA IP
3500 WEST OLIVE AVE.
SUITE 300
BURBANK, CA 91505

EXAMINER

LEE, SUSAN M

ART UNIT PAPER NUMBER

2918

DATE MAILED: 04/09/2014

Determination of Patent Term Extension or Adjustment under 35 U.S.C. 154 (b)

Design patents have a term measured from the issue date of the patent and the term remains the same length regardless of the time that the application for the design patent was pending. Since the above-identified application is an application for a design patent, the patent is not eligible for Patent Term Extension or Adjustment under 35 U.S.C. 154(b).

Any questions regarding the Patent Term Extension or Adjustment determination should be directed to the Office of Patent Legal Administration at (571)-272-7702. Questions relating to issue and publication fee payments should be directed to the Customer Service Center of the Office of Patent Publication at 1-(888)-786-0101 or (571)-272-4200.

OMB Clearance and PRA Burden Statement for PTOL-85 Part B

The Paperwork Reduction Act (PRA) of 1995 requires Federal agencies to obtain Office of Management and Budget approval before requesting most types of information from the public. When OMB approves an agency request to collect information from the public, OMB (i) provides a valid OMB Control Number and expiration date for the agency to display on the instrument that will be used to collect the information and (ii) requires the agency to inform the public about the OMB Control Number's legal significance in accordance with 5 CFR 1320.5(b).

The information collected by PTOL-85 Part B is required by 37 CFR 1.311. The information is required to obtain or retain a benefit by the public which is to file (and by the USPTO to process) an application. Confidentiality is governed by 35 U.S.C. 122 and 37 CFR 1.14. This collection is estimated to take 12 minutes to complete, including gathering, preparing, and submitting the completed application form to the USPTO. Time will vary depending upon the individual case. Any comments on the amount of time you require to complete this form and/or suggestions for reducing this burden, should be sent to the Chief Information Officer, U.S. Patent and Trademark Office, U.S. Department of Commerce, P.O. Box 1450, Alexandria, Virginia 22313-1450. DO NOT SEND FEES OR COMPLETED FORMS TO THIS ADDRESS. SEND TO: Commissioner for Patents, P.O. Box 1450, Alexandria, Virginia 22313-1450. Under the Paperwork Reduction Act of 1995, no persons are required to respond to a collection of information unless it displays a valid OMB control number.

Privacy Act Statement

The Privacy Act of 1974 (P.L. 93-579) requires that you be given certain information in connection with your submission of the attached form related to a patent application or patent. Accordingly, pursuant to the requirements of the Act, please be advised that: (1) the general authority for the collection of this information is 35 U.S.C. 2(b)(2); (2) furnishing of the information solicited is voluntary; and (3) the principal purpose for which the information is used by the U.S. Patent and Trademark Office is to process and/or examine your submission related to a patent application or patent. If you do not furnish the requested information, the U.S. Patent and Trademark Office may not be able to process and/or examine your submission, which may result in termination of proceedings or abandonment of the application or expiration of the patent.

The information provided by you in this form will be subject to the following routine uses:

1. The information on this form will be treated confidentially to the extent allowed under the Freedom of Information Act (5 U.S.C. 552) and the Privacy Act (5 U.S.C. 552a). Records from this system of records may be disclosed to the Department of Justice to determine whether disclosure of these records is required by the Freedom of Information Act.
2. A record from this system of records may be disclosed, as a routine use, in the course of presenting evidence to a court, magistrate, or administrative tribunal, including disclosures to opposing counsel in the course of settlement negotiations.
3. A record in this system of records may be disclosed, as a routine use, to a Member of Congress submitting a request involving an individual, to whom the record pertains, when the individual has requested assistance from the Member with respect to the subject matter of the record.
4. A record in this system of records may be disclosed, as a routine use, to a contractor of the Agency having need for the information in order to perform a contract. Recipients of information shall be required to comply with the requirements of the Privacy Act of 1974, as amended, pursuant to 5 U.S.C. 552a(m).
5. A record related to an International Application filed under the Patent Cooperation Treaty in this system of records may be disclosed, as a routine use, to the International Bureau of the World Intellectual Property Organization, pursuant to the Patent Cooperation Treaty.
6. A record in this system of records may be disclosed, as a routine use, to another federal agency for purposes of National Security review (35 U.S.C. 181) and for review pursuant to the Atomic Energy Act (42 U.S.C. 218(c)).
7. A record from this system of records may be disclosed, as a routine use, to the Administrator, General Services, or his/her designee, during an inspection of records conducted by GSA as part of that agency's responsibility to recommend improvements in records management practices and programs, under authority of 44 U.S.C. 2904 and 2906. Such disclosure shall be made in accordance with the GSA regulations governing inspection of records for this purpose, and any other relevant (i.e., GSA or Commerce) directive. Such disclosure shall not be used to make determinations about individuals.
8. A record from this system of records may be disclosed, as a routine use, to the public after either publication of the application pursuant to 35 U.S.C. 122(b) or issuance of a patent pursuant to 35 U.S.C. 151. Further, a record may be disclosed, subject to the limitations of 37 CFR 1.14, as a routine use, to the public if the record was filed in an application which became abandoned or in which the proceedings were terminated and which application is referenced by either a published application, an application open to public inspection or an issued patent.
9. A record from this system of records may be disclosed, as a routine use, to a Federal, State, or local law enforcement agency, if the USPTO becomes aware of a violation or potential violation of law or regulation.

Notice of Allowability For A Design Application	Application No. 29/480,113	Applicant(s) HAZEL, ARCHIE	
	Examiner SUSAN M. LEE	Art Unit 2918	AIA (First Inventor to File) Status Yes

-- The MAILING DATE of this communication appears on the cover sheet with the correspondence address--

All claims being allowable, PROSECUTION ON THE MERITS IS (OR REMAINS) CLOSED in this application. If not included herewith (or previously mailed), a Notice of Allowance (PTOL-85) or other appropriate communication will be mailed in due course. **THIS NOTICE OF ALLOWABILITY IS NOT A GRANT OF PATENT RIGHTS.** This application is subject to withdrawal from issue at the initiative of the Office or upon petition by the applicant. See 37 CFR 1.313 and MPEP 1308.

1. This communication is responsive to _____.
 A declaration(s)/affidavit(s) under **37 CFR 1.130(b)** was/were filed on _____.
2. An election was made by the applicant in response to a restriction requirement set forth during the interview on _____; the restriction requirement and election have been incorporated into this action.
3. The claim is allowed.
4. Acceptable drawings:
(a) The drawings filed on _____ are accepted by the Examiner.
(b) Drawing Figures filed on _____ and drawing Figures filed on _____ are accepted by the Examiner.
5. The claim for foreign priority under 35 U.S.C. § 119(a)-(d) or (f) is acknowledged.

Certified copies:

- a) All b) Some *c) None of the:
1. Certified copies of the priority documents have been received.
 2. Certified copies of the priority documents have been received in Application No. _____.
 3. Copies of the certified copies of the priority documents have been received in this national stage application from the International Bureau (PCT Rule 17.2(a)).
- * Certified copies not received: _____.

Applicant has THREE MONTHS FROM THE "MAILING DATE" of this communication to file a reply complying with the requirements noted below. Failure to timely comply will result in ABANDONMENT of this application.
THIS THREE-MONTH PERIOD IS NOT EXTENDABLE.

6. CORRECTED DRAWINGS (as "replacement sheets") must be submitted.
 including changes required by the attached Examiner's Amendment / Comment or in the Office action of Paper No./Mail Date _____.

Identifying indicia such as the application number (see 37 CFR 1.84(c)) should be written on the drawings in the front (not the back) of each sheet. Replacement sheet(s) should be labeled as such in the header according to 37 CFR 1.121(d).

Attachment(s)

- | | |
|--|---|
| <ol style="list-style-type: none"> 1. <input checked="" type="checkbox"/> Notice of References Cited (PTO-892) 2. <input type="checkbox"/> Information Disclosure Statements (PTO/SB/08),
Paper No./Receipt Date _____ 3. <input type="checkbox"/> Interview Summary (PTO-413),
Paper No./Mail Date _____ | <ol style="list-style-type: none"> 4. <input checked="" type="checkbox"/> Examiner's Amendment/Comment 5. <input type="checkbox"/> Examiner's Statement of Reasons for Allowance 6. <input type="checkbox"/> Other _____ |
|--|---|

NOTE:

**Note: The present application, filed on or after March 16, 2013, is being examined under the first inventor to file provisions of the AIA.*

Examiner's Comment: Required Drawing Correction

For utmost clarity in the depiction of the disclaimed portion, it is requested that applicant kindly amend the Fig. 8 drawing in the following manner: A broken line should be run alongside the spine of the partition. For applicant's reference, here is an annotated example:

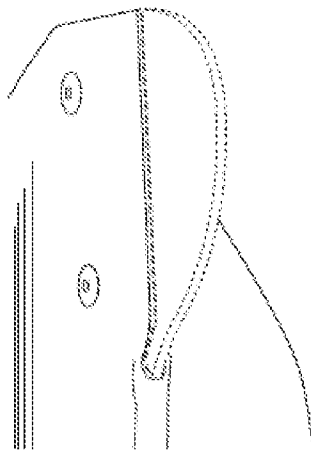

Corrected drawing sheets are required in reply to the Office action to avoid abandonment of the application. Any amended replacement drawing sheet should include all of the figures appearing on the immediate prior version of the sheet, even if only one figure is being amended. The figure or figure number of an amended drawing should not be labeled as "amended." Each drawing sheet submitted after the filing date of an application must be labeled in the top margin as either "Replacement Sheet" or "New Sheet" pursuant to 37 CFR 1.121(d).

Art Unit: 2918

Examiner's Amendment

An examiner's amendment to the record appears below. Should the changes and/or additions be unacceptable to applicant, an amendment may be filed as provided by 37 CFR 1.312. To ensure consideration of such an amendment, it MUST be submitted no later than the payment of the issue fee.

Specification

For utmost clarity and preferred form, the Fig. 8 description is here now amended and a broken line description statement inserted, to read as follows:

>> Fig. 8 is an enlarged perspective view of a single partition.

Broken lines and unshaded portions contained within broken lines are not claimed. <<

Any inquiry concerning this communication or earlier communications from the examiner may be directed to Susan M. Lee whose telephone number is 5712726027. The fax phone number for the organization where this application or proceeding is assigned is 571-273-8300.

/SUSAN MOON LEE/

PRIMARY EXAMINER

Notice of References Cited	Application/Control No. 29/480,113	Applicant(s)/Patent Under Reexamination HAZEL, ARCHIE	
	Examiner SUSAN M. LEE	Art Unit 2918	Page 1 of 13

U.S. PATENT DOCUMENTS

*	Document Number Country Code-Number-Kind Code	Date MM-YYYY	Name	Classification	
*	A	US- D28,734 S	05-1898	Muller,H.	D26/101
*	B	US-721,435 A	02-1903	Fielding,P.	362/311.06
*	C	US- D62,916 S	08-1923	Peck,E.	D26/24
*	D	US- D71,107 S	09-1926	Gorowitz,L.	D26/101
*	E	US- D76,001 S	08-1928	Broch,J.	D6/412
*	F	US- D84,104 S	05-1931	Rithner,H.	D26/127
*	G	US- D95,019 S	04-1935	Cooperstein,A.	D11/146
*	H	US-D121,675 S	07-1940	Goldin,W.	D11/117
*	I	US-D130,923 S	12-1941	Philipovich,S.	D26/101
*	J	US-D140,392 S	02-1945	Haynes,R.	D11/139
*	K	US-2,432,632 A	12-1947	SEIBEL PHILLIP H	362/567
*	L	US-D149,729 S	05-1948	Aronek,M.	D26/101
*	M	US-2,570,733 A	10-1951	THOMAS WILLIAM G	119/72

FOREIGN PATENT DOCUMENTS

*	Document Number Country Code-Number-Kind Code	Date MM-YYYY	Country	Name	Classification
	N				
	O				
	P				
	Q				
	R				
	S				
	T				

NON-PATENT DOCUMENTS

*	Document Number Country Code-Number-Kind Code	Date MM-YYYY	Country	Name	Classification
		Include as applicable: Author, Title Date, Publisher, Edition or Volume, Pertinent Pages)			
	U				
	V				
	W				
	X				

*A copy of this reference is not being furnished with this Office action. (See MPEP § 707.05(a).)
Dates in MM-YYYY format are publication dates. Classifications may be US or foreign.

Notice of References Cited	Application/Control No. 29/480,113	Applicant(s)/Patent Under Reexamination HAZEL, ARCHIE	
	Examiner SUSAN M. LEE	Art Unit 2918	Page 2 of 13

U.S. PATENT DOCUMENTS

*	Document Number Country Code-Number-Kind Code	Date MM-YYYY	Name	Classification	
*	A	US-2,641,086 A	06-1953	STEPHEN SHINODA DANIEL	47/55
*	B	US-D174,909 S	06-1955	Killegberg,A.	D11/151
*	C	US-D175,435 S	08-1955	Moffat,G.	D11/151
*	D	US-3,050,619 A	08-1962	ABRAHAM ABRAMSON	362/122
*	E	US-D194,846 S	03-1963	Perry,R.	D30/125
*	F	US-3,125,069 A	03-1964	Fowler,B.	119/77
*	G	US-D200,472 S	03-1965	Chang,K.	D11/117
*	H	US-D214,172 S	05-1969	Troutman,L.	D11/151
*	I	US-3,634,678 A	01-1972	Glass et al.	362/567
*	J	US-3,913,527 A	10-1975	Kilham, Peter	119/74
*	K	US-3,928,936 A	12-1975	Wollen, Dennis J.	47/41.15
*	L	US-D239,182 S	03-1976	Kilham,P.	D30/125
*	M	US-4,037,361 A	07-1977	Murphy et al.	47/48.5

FOREIGN PATENT DOCUMENTS

*	Document Number Country Code-Number-Kind Code	Date MM-YYYY	Country	Name	Classification
	N				
	O				
	P				
	Q				
	R				
	S				
	T				

NON-PATENT DOCUMENTS

*	Document Number Country Code-Number-Kind Code	Date MM-YYYY	Country	Name	Classification
		Include as applicable: Author, Title Date, Publisher, Edition or Volume, Pertinent Pages)			
	U				
	V				
	W				
	X				

*A copy of this reference is not being furnished with this Office action. (See MPEP § 707.05(a).)
Dates in MM-YYYY format are publication dates. Classifications may be US or foreign.

Notice of References Cited	Application/Control No. 29/480,113	Applicant(s)/Patent Under Reexamination HAZEL, ARCHIE	
	Examiner SUSAN M. LEE	Art Unit 2918	Page 3 of 13

U.S. PATENT DOCUMENTS

*		Document Number Country Code-Number-Kind Code	Date MM-YYYY	Name	Classification
*	A	US-D246,294 S	11-1977	Hetherington, Susan Kaye	D11/117
*	B	US-4,082,872 A	04-1978	Hughes, James L.	428/24
*	C	US-D252,288 S	07-1979	Kilham, Peter	D30/125
*	D	US-4,369,216 A	01-1983	Willinger, Allan H.	428/17
*	E	US-D281,768 S	12-1985	Hansen, Jr., H. Roland	D11/117
*	F	US-4,588,618 A	05-1986	Wolfe, Henry S.	428/7
*	G	US-D287,652 S	01-1987	Mack, John D.	D30/128
*	H	US-D288,353 S	02-1987	Smith, Vance	D23/285
*	I	US-4,691,665 A	09-1987	Hefner, Boby R.	119/77
*	J	US-4,708,892 A	11-1987	Young et al.	428/24
*	K	US-4,789,572 A	12-1988	Weaver, Ronald A.	428/26
*	L	US-D309,639 S	07-1990	Knudsen, Jens N.	D21/496
*	M	US-D309,640 S	07-1990	Knudsen, Jens N.	D21/496

FOREIGN PATENT DOCUMENTS

*		Document Number Country Code-Number-Kind Code	Date MM-YYYY	Country	Name	Classification
	N					
	O					
	P					
	Q					
	R					
	S					
	T					

NON-PATENT DOCUMENTS

*		Include as applicable: Author, Title Date, Publisher, Edition or Volume, Pertinent Pages)
	U	
	V	
	W	
	X	

*A copy of this reference is not being furnished with this Office action. (See MPEP § 707.05(a).)
Dates in MM-YYYY format are publication dates. Classifications may be US or foreign.

Notice of References Cited	Application/Control No. 29/480,113	Applicant(s)/Patent Under Reexamination HAZEL, ARCHIE	
	Examiner SUSAN M. LEE	Art Unit 2918	Page 4 of 13

U.S. PATENT DOCUMENTS

*	Document Number Country Code-Number-Kind Code	Date MM-YYYY	Name	Classification	
*	A	US-D322,044 S	12-1991	Marsar et al.	D11/117
*	B	US-5,083,881 A	01-1992	Yoshinaga, Sadao	401/195
*	C	US-D331,864 S	12-1992	Sciubba, Robert	D8/1
*	D	US-D345,444 S	03-1994	Kestekides-Kesdekoglu, Maria	D1/127
*	E	US-D360,710 S	07-1995	Colwell, Betsy P.	D30/121
*	F	US-5,450,816 A	09-1995	Santa Cruz, Tonya A.	119/72
*	G	US-D365,411 S	12-1995	Yan, San-Jyh	D26/125
*	H	US-5,507,249 A	04-1996	Shaw, Harry J.	119/72
*	I	US-D368,989 S	04-1996	Prehart, Kenneth	D30/111
*	J	US-5,522,758 A	06-1996	Liu et al.	446/310
*	K	US-D371,401 S	07-1996	Nielsen et al.	D21/496
*	L	US-D371,838 S	07-1996	Davis et al.	D23/411
*	M	US-D378,312 S	03-1997	Davis, Jr., William S.	D23/411

FOREIGN PATENT DOCUMENTS

*	Document Number Country Code-Number-Kind Code	Date MM-YYYY	Country	Name	Classification
	N				
	O				
	P				
	Q				
	R				
	S				
	T				

NON-PATENT DOCUMENTS

*	Document Number Country Code-Number-Kind Code	Date MM-YYYY	Country	Name	Classification
		Include as applicable: Author, Title Date, Publisher, Edition or Volume, Pertinent Pages)			
	U				
	V				
	W				
	X				

*A copy of this reference is not being furnished with this Office action. (See MPEP § 707.05(a).)
Dates in MM-YYYY format are publication dates. Classifications may be US or foreign.

Notice of References Cited	Application/Control No. 29/480,113	Applicant(s)/Patent Under Reexamination HAZEL, ARCHIE	
	Examiner SUSAN M. LEE	Art Unit 2918	Page 5 of 13

U.S. PATENT DOCUMENTS

*	Document Number Country Code-Number-Kind Code	Date MM-YYYY	Name	Classification	
*	A	US-D382,376 S	08-1997	Bescherer, Robert E.	D30/124
*	B	US-D386,811 S	11-1997	Milicia, Libbe A.	D26/156
*	C	US-5,682,835 A	11-1997	Walter et al.	119/57.8
*	D	US-D388,235 S	12-1997	Wilson et al.	D1/115
*	E	US-D387,156 S	12-1997	Johnson, Aaron M.	D23/411
*	F	US-D392,763 S	03-1998	Denison et al.	D26/68
*	G	US-D394,468 S	05-1998	Leadbetter, Paul	D21/496
*	H	US-D397,529 S	08-1998	Fuller et al.	D30/124
*	I	US-5,806,460 A	09-1998	Klein, Arnold G.	119/72
*	J	US-5,800,047 A	09-1998	Yang, Chin Ying	362/255
*	K	US-5,816,686 A	10-1998	Wang et al.	362/653
*	L	US-5,848,493 A	12-1998	Gaspar, Ekkehart	47/41.15
*	M	US-5,899,555 A	05-1999	Lin, Mei-Lu	362/122

FOREIGN PATENT DOCUMENTS

*	Document Number Country Code-Number-Kind Code	Date MM-YYYY	Country	Name	Classification
	N				
	O				
	P				
	Q				
	R				
	S				
	T				

NON-PATENT DOCUMENTS

*	Document Number Country Code-Number-Kind Code	Date MM-YYYY	Country	Name	Classification
	Include as applicable: Author, Title Date, Publisher, Edition or Volume, Pertinent Pages)				
	U				
	V				
	W				
	X				

*A copy of this reference is not being furnished with this Office action. (See MPEP § 707.05(a).)
Dates in MM-YYYY format are publication dates. Classifications may be US or foreign.

Notice of References Cited	Application/Control No. 29/480,113	Applicant(s)/Patent Under Reexamination HAZEL, ARCHIE	
	Examiner SUSAN M. LEE	Art Unit 2918	Page 6 of 13

U.S. PATENT DOCUMENTS

*	Document Number Country Code-Number-Kind Code	Date MM-YYYY	Name	Classification
*	A	US-6,012,414 A	Klein, Arnold G.	119/72
*	B	US-D421,643 S	Mauk, Mitchell	D23/261
*	C	US-D433,747 S	Frampton, Thomas C.	D23/413
*	D	US-D443,711 S	Lindsay, Lance Trimble	D26/68
*	E	US-D445,533 S	Arnoldo, Bandini	D26/127
*	F	US-D450,786 S	Jenkins et al.	D21/577
*	G	US-D451,997 S	Schwartz, Gerald	D23/413
*	H	US-D454,636 S	Lantz, Paul R.	D23/413
*	I	US-D454,192 S	Frampton, Thomas C.	D23/413
*	J	US-D454,669 S	Lieb, Robert Paul	D30/125
*	K	US-D459,824 S	Leen, Monte A.	D26/73
*	L	US-6,439,158 B1	Blohm, Walter	119/57.8
*	M	US-6,499,430 B2	Garcia-Lucio et al.	119/72

FOREIGN PATENT DOCUMENTS

*	Document Number Country Code-Number-Kind Code	Date MM-YYYY	Country	Name	Classification
	N				
	O				
	P				
	Q				
	R				
	S				
	T				

NON-PATENT DOCUMENTS

*	Document Number Country Code-Number-Kind Code	Date MM-YYYY	Country	Name	Classification
		Include as applicable: Author, Title Date, Publisher, Edition or Volume, Pertinent Pages)			
	U				
	V				
	W				
	X				

*A copy of this reference is not being furnished with this Office action. (See MPEP § 707.05(a).)
Dates in MM-YYYY format are publication dates. Classifications may be US or foreign.

Notice of References Cited	Application/Control No. 29/480,113	Applicant(s)/Patent Under Reexamination HAZEL, ARCHIE	
	Examiner SUSAN M. LEE	Art Unit 2918	Page 7 of 13

U.S. PATENT DOCUMENTS

*	Document Number Country Code-Number-Kind Code	Date MM-YYYY	Name	Classification	
*	A	US-D470,621 S	02-2003	Cheng, Hung-Huei	D26/127
*	B	US-D476,755 S	07-2003	LoVullo et al.	D26/25
*	C	US-D480,135 S	09-2003	Frampton, Thomas C.	D23/413
*	D	US-D479,597 S	09-2003	Curtin, Brett	D23/413
*	E	US-D479,595 S	09-2003	Curtin, Brett	D23/413
*	F	US-D479,596 S	09-2003	Curtin, Brett	D23/413
*	G	US-D480,802 S	10-2003	Frampton, Thomas C.	D23/413
*	H	US-D480,803 S	10-2003	Frampton, Thomas C.	D23/413
*	I	US-D482,736 S	11-2003	Manville, Richard B.	D21/484
*	J	US-D483,858 S	12-2003	Lin, Fan-Yee	D23/413
*	K	US-2004/0010971 A1	01-2004	Redfield et al.	47/83
*	L	US-D485,350 S	01-2004	Frampton, Thomas C.	D23/413
*	M	US-6,672,249 B2	01-2004	Garcia-Lucio et al.	119/72

FOREIGN PATENT DOCUMENTS

*	Document Number Country Code-Number-Kind Code	Date MM-YYYY	Country	Name	Classification
	N				
	O				
	P				
	Q				
	R				
	S				
	T				

NON-PATENT DOCUMENTS

*	Document Number Country Code-Number-Kind Code	Date MM-YYYY	Country	Name	Classification
	Include as applicable: Author, Title Date, Publisher, Edition or Volume, Pertinent Pages)				
	U				
	V				
	W				
	X				

*A copy of this reference is not being furnished with this Office action. (See MPEP § 707.05(a).)
Dates in MM-YYYY format are publication dates. Classifications may be US or foreign.

Notice of References Cited	Application/Control No. 29/480,113	Applicant(s)/Patent Under Reexamination HAZEL, ARCHIE	
	Examiner SUSAN M. LEE	Art Unit 2918	Page 8 of 13

U.S. PATENT DOCUMENTS

*	Document Number Country Code-Number-Kind Code	Date MM-YYYY	Name	Classification
*	A US-D485,345 S	01-2004	Bucher, John C.	D23/377
*	B US-D485,351 S	01-2004	Frampton, Thomas C.	D23/413
*	C US-D488,195 S	04-2004	Manville, Richard B.	D21/484
*	D US-D488,219 S	04-2004	Frampton, Thomas C.	D23/413
*	E US-D489,128 S	04-2004	Frampton, Thomas C.	D23/413
*	F US-6,733,151 B2	05-2004	Shu, Kuo-Fen	362/122
*	G US-2004/0118354 A1	06-2004	Cox et al.	119/072
*	H US-D491,657 S	06-2004	Cartwright, Thomas	D23/413
*	I US-6,776,511 B1	08-2004	Lindsay, Lance Trimble	362/377
*	J US-D502,293 S	02-2005	Harger, James Robert	D30/124
*	K US-6,861,108 B1	03-2005	Potoroka, Sr., Walter	428/17
*	L US-6,890,155 B2	05-2005	Cartwright, Thomas	416/229R
*	M US-D506,826 S	06-2005	Frampton, Thomas C.	D23/411

FOREIGN PATENT DOCUMENTS

*	Document Number Country Code-Number-Kind Code	Date MM-YYYY	Country	Name	Classification
N					
O					
P					
Q					
R					
S					
T					

NON-PATENT DOCUMENTS

*	Document Number Country Code-Number-Kind Code	Date MM-YYYY	Country	Name	Classification
		Include as applicable: Author, Title Date, Publisher, Edition or Volume, Pertinent Pages)			
U					
V					
W					
X					

*A copy of this reference is not being furnished with this Office action. (See MPEP § 707.05(a).)
Dates in MM-YYYY format are publication dates. Classifications may be US or foreign.

Notice of References Cited	Application/Control No. 29/480,113	Applicant(s)/Patent Under Reexamination HAZEL, ARCHIE	
	Examiner SUSAN M. LEE	Art Unit 2918	Page 9 of 13

U.S. PATENT DOCUMENTS

*		Document Number Country Code-Number-Kind Code	Date MM-YYYY	Name	Classification
*	A	US-D510,992 S	10-2005	Bucher, John C.	D23/377
*	B	US-D516,712 S	03-2006	Pickett, Mark	D23/413
*	C	US-D523,955 S	06-2006	Badarello, Christophe	D23/413
*	D	US-D525,903 S	08-2006	Weiser et al.	D11/117
*	E	US-D536,838 S	02-2007	Colvin et al.	D30/124
*	F	US-D538,485 S	03-2007	Degironne, Charles M.	D30/124
*	G	US-D541,466 S	04-2007	Bucher et al.	D26/113
*	H	US-7,234,418 B2	06-2007	Fort et al.	119/72
*	I	US-D548,321 S	08-2007	Orozco, Sergio	D23/411
*	J	US-D554,252 S	10-2007	Bucher et al.	D23/413
*	K	US-D563,616 S	03-2008	Lynde et al.	D32/40
*	L	US-D565,173 S	03-2008	Bucher et al.	D23/413
*	M	US-D569,301 S	05-2008	Fotherby, Victor M.	D11/117

FOREIGN PATENT DOCUMENTS

*		Document Number Country Code-Number-Kind Code	Date MM-YYYY	Country	Name	Classification
	N					
	O					
	P					
	Q					
	R					
	S					
	T					

NON-PATENT DOCUMENTS

*		Include as applicable: Author, Title Date, Publisher, Edition or Volume, Pertinent Pages)
	U	
	V	
	W	
	X	

*A copy of this reference is not being furnished with this Office action. (See MPEP § 707.05(a).)
Dates in MM-YYYY format are publication dates. Classifications may be US or foreign.

Notice of References Cited	Application/Control No. 29/480,113	Applicant(s)/Patent Under Reexamination HAZEL, ARCHIE	
	Examiner SUSAN M. LEE	Art Unit 2918	Page 10 of 13

U.S. PATENT DOCUMENTS

*		Document Number Country Code-Number-Kind Code	Date MM-YYYY	Name	Classification
*	A	US-7,396,212 B1	07-2008	Parker et al.	416/243
*	B	US-D575,864 S	08-2008	Parker et al.	D23/413
*	C	US-7,448,347 B2	11-2008	Richmond, Simon Nicholas	119/72
*	D	US-D584,387 S	01-2009	Lee et al.	D23/285
*	E	US-D588,756 S	03-2009	Colvin et al.	D30/124
*	F	US-D593,649 S	06-2009	Marvell, Kristan	D23/285
*	G	US-D595,525 S	07-2009	Dimond, Debra A.	D6/597
*	H	US-D597,197 S	07-2009	Parker et al.	D23/413
*	I	US-7,600,487 B2	10-2009	Stone et al.	119/72
*	J	US-2009/0320765 A1	12-2009	Gauker et al.	119/75
*	K	US-D606,878 S	12-2009	Lindfors, Stefan	D9/666
*	L	US-D606,708 S	12-2009	McMullen, Joseph E.	D30/127
*	M	US-D609,329 S	02-2010	Parker et al.	D23/411

FOREIGN PATENT DOCUMENTS

*		Document Number Country Code-Number-Kind Code	Date MM-YYYY	Country	Name	Classification
	N					
	O					
	P					
	Q					
	R					
	S					
	T					

NON-PATENT DOCUMENTS

*		Include as applicable: Author, Title Date, Publisher, Edition or Volume, Pertinent Pages)
	U	
	V	
	W	
	X	

*A copy of this reference is not being furnished with this Office action. (See MPEP § 707.05(a).)
Dates in MM-YYYY format are publication dates. Classifications may be US or foreign.

Notice of References Cited	Application/Control No. 29/480,113	Applicant(s)/Patent Under Reexamination HAZEL, ARCHIE	
	Examiner SUSAN M. LEE	Art Unit 2918	Page 11 of 13

U.S. PATENT DOCUMENTS

*	Document Number Country Code-Number-Kind Code	Date MM-YYYY	Name	Classification	
*	A	US-7,685,969 B2	03-2010	Stone et al.	119/72
*	B	US-D615,310 S	05-2010	Cybulski, Peter	D6/348
*	C	US-D620,172 S	07-2010	Orozco, Sergio	D26/73
*	D	US-7,789,040 B2	09-2010	Liethen, Frederic J.	119/57.8
*	E	US-D627,457 S	11-2010	Klausing et al.	D23/413
*	F	US-D629,137 S	12-2010	Chen, Chi Gon	D26/68
*	G	US-7,861,671 B2	01-2011	Carter et al.	119/72
*	H	US-D630,969 S	01-2011	Mattis, James F.	D11/117
*	I	US-D641,516 S	07-2011	Chen, Chi Gon	D26/68
*	J	US-8,011,323 B2	09-2011	Vaughn et al.	119/72
*	K	US-8,051,803 B2	11-2011	Gauker et al.	119/81
*	L	US-D650,514 S	12-2011	Lin et al.	D26/118
*	M	US-2011/0011345	01-2011	LoRocco et al.	119/72

FOREIGN PATENT DOCUMENTS

*	Document Number Country Code-Number-Kind Code	Date MM-YYYY	Country	Name	Classification
N					
O					
P					
Q					
R					
S					
T					

NON-PATENT DOCUMENTS

*	Document Number Country Code-Number-Kind Code	Date MM-YYYY	Country	Name	Classification
		Include as applicable: Author, Title Date, Publisher, Edition or Volume, Pertinent Pages)			
U					
V					
W					
X					

*A copy of this reference is not being furnished with this Office action. (See MPEP § 707.05(a).)
Dates in MM-YYYY format are publication dates. Classifications may be US or foreign.

Notice of References Cited	Application/Control No. 29/480,113	Applicant(s)/Patent Under Reexamination HAZEL, ARCHIE	
	Examiner SUSAN M. LEE	Art Unit 2918	Page 12 of 13

U.S. PATENT DOCUMENTS

*		Document Number Country Code-Number-Kind Code	Date MM-YYYY	Name	Classification
*	A	US-2009/0308321	12-2009	Szczygiel- Durante, Lisa	119/72
*	B	US-2010/0024738	02-2010	CHEN et al.	119/72
*	C	US-2010/0224132	09-2010	Gauker et al.	119/80
*	D	US-2013/0239478	09-2013	Weder, Donald E.	47/72
*	E	US-5,771,614	06-1998	Dawson, Neil K.	40/124.06
*	F	US-4,446,178	05-1984	Daugherty, Yvonne B.	428/26
*	G	US-D698,501	01-2014	Muhr et al.	D30/124
*	H	US-D698,102	01-2014	Muhr et al.	D30/124
*	I	US-D698,101	01-2014	Muhr et al.	D30/124
*	J	US-D698,100	01-2014	Muhr et al.	D30/124
*	K	US-D698,099	01-2014	Muhr et al.	D30/124
*	L	US-D698,098	01-2014	Muhr et al.	D30/124
*	M	US-D211,887	08-1968	Name not available	D6/539

FOREIGN PATENT DOCUMENTS

*		Document Number Country Code-Number-Kind Code	Date MM-YYYY	Country	Name	Classification
	N					
	O					
	P					
	Q					
	R					
	S					
	T					

NON-PATENT DOCUMENTS

*		Include as applicable: Author, Title Date, Publisher, Edition or Volume, Pertinent Pages)
	U	
	V	
	W	
	X	

*A copy of this reference is not being furnished with this Office action. (See MPEP § 707.05(a).)
Dates in MM-YYYY format are publication dates. Classifications may be US or foreign.

Notice of References Cited	Application/Control No. 29/480,113	Applicant(s)/Patent Under Reexamination HAZEL, ARCHIE	
	Examiner SUSAN M. LEE	Art Unit 2918	Page 13 of 13

U.S. PATENT DOCUMENTS

*	Document Number Country Code-Number-Kind Code	Date MM-YYYY	Name	Classification
*	A US-3,137,610	06-1964	ANNELIE FLYNN	428/26
*	B US-2,881,545	04-1959	EMILE DECAMP ANDRE	428/26
*	C US-4,293,601	10-1981	Cole, Bernard M.	428/24
*	D US-2,140,022	12-1938	MARTIN WILLIAM F	428/24
*	E US-899,852	09-1908	Warner,W.	428/24
*	F US-290,118	12-1883	Sargent,J.	428/24
*	G US-D698,129	01-2014	Marz, Keith	D2/858
*	H US-D193,760	10-1962	Sanders,F.	D2/858
*	I US-D402,441	12-1998	Kelly, Jim E.	D2/858
*	J US-D240,777	08-1976	Petersen,P.	D2/858
*	K US-D65,027	06-1924	Wade,K.	D21/628
	L US-			
	M US-			

FOREIGN PATENT DOCUMENTS

*	Document Number Country Code-Number-Kind Code	Date MM-YYYY	Country	Name	Classification
	N				
	O				
	P				
	Q				
	R				
	S				
	T				

NON-PATENT DOCUMENTS

*	Document Number Country Code-Number-Kind Code	Date MM-YYYY	Country	Name	Classification
	Include as applicable: Author, Title Date, Publisher, Edition or Volume, Pertinent Pages)				
	U				
	V				
	W				
	X				

*A copy of this reference is not being furnished with this Office action. (See MPEP § 707.05(a).)
Dates in MM-YYYY format are publication dates. Classifications may be US or foreign.

Issue Classification 	Application/Control No. 29480113	Applicant(s)/Patent Under Reexamination HAZEL, ARCHIE
	Examiner SUSAN M LEE	Art Unit 2918

CPC			Type	Version
Symbol				

CPC Combination Sets				
Symbol	Type	Set	Ranking	Version

NONE (Assistant Examiner) /SUSAN MOON LEE/ Primary Examiner. Art Unit 2918 (Primary Examiner)	(Date) 4/2/2014 (Date)	<input type="checkbox"/> Use images from artifact folder <input checked="" type="checkbox"/> Do not use images from artifact folder	Total Claims Allowed: 1	O.G. Print Claim(s) 1	O.G. Print Figure 4 and 6
---	--------------------------------------	--	---------------------------------------	------------------------------	----------------------------------

<i>Issue Classification</i> 	Application/Control No. 29480113	Applicant(s)/Patent Under Reexamination HAZEL, ARCHIE
	Examiner SUSAN M LEE	Art Unit 2918

US ORIGINAL CLASSIFICATION					INTERNATIONAL CLASSIFICATION											
CLASS		SUBCLASS			CLAIMED				NON-CLAIMED							
D30		124														
CROSS REFERENCE(S)																
CLASS	SUBCLASS (ONE SUBCLASS PER BLOCK)															

NONE (Assistant Examiner) _____ (Date) _____ /SUSAN MOON LEE/ Primary Examiner. Art Unit 2918 (Primary Examiner) _____ (Date) _____	<input type="checkbox"/> Use images from artifact folder <input type="checkbox"/> Do not use images from artifact folder	Total Claims Allowed: 1 <table border="1" style="width: 100%;"> <tr> <td style="width: 50%;">O.G. Print Claim(s) 1</td> <td style="width: 50%;">O.G. Print Figure 4 and 6</td> </tr> </table>	O.G. Print Claim(s) 1	O.G. Print Figure 4 and 6
O.G. Print Claim(s) 1	O.G. Print Figure 4 and 6			

Issue Classification 	Application/Control No. 29480113	Applicant(s)/Patent Under Reexamination HAZEL, ARCHIE
	Examiner SUSAN M LEE	Art Unit 2918

<input type="checkbox"/> Claims renumbered in the same order as presented by applicant																<input type="checkbox"/> CPA		<input type="checkbox"/> T.D.		<input type="checkbox"/> R.1.47	
Final	Original	Final	Original	Final	Original	Final	Original	Final	Original	Final	Original	Final	Original	Final	Original						
1	1																				

NONE (Assistant Examiner) _____ (Date) _____		<input checked="" type="checkbox"/> Use images from artifact folder <input checked="" type="checkbox"/> Do not use images from artifact folder	Total Claims Allowed: 1		
/SUSAN MOON LEE/ Primary Examiner. Art Unit 2918 (Primary Examiner) _____ (Date) _____		4/2/2014 (Date)	<table border="1"> <tr> <td>O.G. Print Claim(s) 1</td> <td>O.G. Print Figure 4 and 6</td> </tr> </table>	O.G. Print Claim(s) 1	O.G. Print Figure 4 and 6
O.G. Print Claim(s) 1	O.G. Print Figure 4 and 6				

UNITED STATES PATENT AND TRADEMARK OFFICE

UNITED STATES DEPARTMENT OF COMMERCE
United States Patent and Trademark Office
 Address: COMMISSIONER FOR PATENTS
 P.O. Box 1450
 Alexandria, Virginia 22313-1450
 www.uspto.gov

BIB DATA SHEET
CONFIRMATION NO. 2342

SERIAL NUMBER	FILING or 371(c) DATE RULE	CLASS	GROUP ART UNIT	ATTORNEY DOCKET NO. A.HAZ-003	
29/480,113	01/23/2014	D30	2918		
APPLICANTS INVENTORS Archie Hazel, Jonesboro, IL; ** CONTINUING DATA ***** ** FOREIGN APPLICATIONS ***** ** IF REQUIRED, FOREIGN FILING LICENSE GRANTED ** ** MICRO ENTITY ** 01/28/2014					
Foreign Priority claimed <input type="checkbox"/> Yes <input checked="" type="checkbox"/> No 35 USC 119(a-d) conditions met <input type="checkbox"/> Yes <input type="checkbox"/> No Verified and Acknowledged <u>/SUSAN M LEE/</u> <small>Examiner's Signature</small>	<input type="checkbox"/> Met after Allowance <small>Initials</small>	STATE OR COUNTRY IL	SHEETS DRAWINGS 5	TOTAL CLAIMS 1	INDEPENDENT CLAIMS 1
ADDRESS ITALIA IP 3500 WEST OLIVE AVE. SUITE 300 BURBANK, CA 91505 UNITED STATES					
TITLE HUMMINGBIRD FEEDER PARTITION					
FILING FEE RECEIVED 190	FEES: Authority has been given in Paper No. _____ to charge/credit DEPOSIT ACCOUNT No. _____ for following:		<input type="checkbox"/> All Fees <input type="checkbox"/> 1.16 Fees (Filing) <input type="checkbox"/> 1.17 Fees (Processing Ext. of time) <input type="checkbox"/> 1.18 Fees (Issue) <input type="checkbox"/> Other _____ <input type="checkbox"/> Credit		

Search Notes 	Application/Control No. 29480113	Applicant(s)/Patent Under Reexamination HAZEL, ARCHIE
	Examiner SUSAN M LEE	Art Unit 2918

CPC- SEARCHED		
Symbol	Date	Examiner

CPC COMBINATION SETS - SEARCHED		
Symbol	Date	Examiner

US CLASSIFICATION SEARCHED			
Class	Subclass	Date	Examiner
D30	121,124-128,110,115,117,119	3/29/2014	/SML/
119	51.01,57.8,53,428,429,469		/SML/
D11	139,117-120,130,131,151,184		

SEARCH NOTES		
Search Notes	Date	Examiner
PALM Inventor Name Search	3/29/2014	/SML/
EAST database		/SML/
GOOGLE		/SML/
Princeton box of various animal product catalogues and clippings		/SML/

INTERFERENCE SEARCH			
US Class/ CPC Symbol	US Subclass / CPC Group	Date	Examiner
D30	124	3/29/2014	/SML/

	/S.M.L./ Primary Examiner.Art Unit 2918
--	--



UNITED STATES PATENT AND TRADEMARK OFFICE

Commissioner for Patents
United States Patent and Trademark Office
P.O. Box 1450
Alexandria, VA 22313-1450
www.uspto.gov

In re Application of :
Hazel, Archie : DECISION ON PETITION
Application No. 29/480,113 : TO MAKE SPECIAL
Filed: January 23, 2014 : 37 CFR 1.102(C)
Attorney Docket No. A.HAZ-003 :

This is a decision on the petition under 37 CFR 1.102(c)(1), filed January 23, 2014, to make the above-identified application special based on applicant's age as set forth in M.P.E.P. § 708.02, Section IV.

The petition is **GRANTED**.

A grantable petition to make an application special under 37 CFR 1.102(c)(1) and MPEP § 708.02, Section IV: Applicant's Age must be accompanied by evidence showing that at least one of the applicants is 65 years of age, or more, such as a birth certificate or a statement by applicant. No fee is required.

The instant petition includes a statement from Archie Hazel's attorney, attesting to the applicant being 65 years of age or more. Accordingly, the above-identified application has been accorded "special" status.

Telephone inquiries concerning this decision should be directed to the undersigned at 571-272-3206. All other inquiries concerning either the examination or status of the application should be directed to the Technology Center.

This matter is being referred to Technology Center Art Unit 2918 for action on the merits commensurate with this decision.

/Liana Walsh/
Liana Walsh
Petitions Paralegal Specialist
Office of Petitions



UNITED STATES PATENT AND TRADEMARK OFFICE

UNITED STATES DEPARTMENT OF COMMERCE
United States Patent and Trademark Office
Address: COMMISSIONER FOR PATENTS
P.O. Box 1450
Alexandria, Virginia 22313-1450
www.uspto.gov

APPLICATION NO.	FILING DATE	FIRST NAMED INVENTOR	ATTORNEY DOCKET NO.	CONFIRMATION NO.
29/480,113	01/23/2014	Archie Hazel	A.HAZ-003	2342
59259	7590	04/03/2014	EXAMINER	
ITALIA IP 3500 WEST OLIVE AVE. SUITE 300 BURBANK, CA 91505			LEE, SUSAN M	
			ART UNIT	PAPER NUMBER
			2918	
			NOTIFICATION DATE	DELIVERY MODE
			04/03/2014	ELECTRONIC

Please find below and/or attached an Office communication concerning this application or proceeding.

The time period for reply, if any, is set in the attached communication.

Notice of the Office communication was sent electronically on above-indicated "Notification Date" to the following e-mail address(es):

ITALIA@ITALIAIP.COM
pto@thepatentoffice.com
jitalia@hotmail.com

Application No.

29480113



For US serial numbers: enter number only, no slashes or commas. Ex: 10123456

For PCT: enter "51+single digit of year of filing+last 5 numbers", Ex. for PCT/US05/12345, enter 51512345

Deciding Official:

WALSH, LIANA

Count (1) - Palm Credit

29/480,113

FINANCE WORK NEEDED

Decision: GRANT

Select Check Box for YES



Decision Type: 601 - TO MAKE APPLICATION SPECIAL ON GROUND C



Notes:

Count (2)

Decision: n/a

FINANCE WORK NEEDED

Select Check Box for YES

Decision Type: NONE

Notes:

Count (3)

Decision: n/a

FINANCE WORK NEEDED

Select Check Box for YES

Decision Type: NONE

Notes:

Initials of Approving Official (if required)

If more than 3 decisions, attach 2nd count sheet & mark this box



Application No.

29480113



For US serial numbers: enter number only, no slashes or commas. Ex: 10123456

For PCT: enter "51+single digit of year of filing+last 5 numbers", Ex. for PCT/US05/12345, enter 51512345

Deciding Official:

WALSH, LIANA

Count (1) - Palm Credit

29/480,113

FINANCE WORK NEEDED

Decision: GRANT

Select Check Box for YES



Decision Type: 601 - TO MAKE APPLICATION SPECIAL ON GROUND C



Notes:

Count (2)

Decision: n/a

FINANCE WORK NEEDED

Select Check Box for YES

Decision Type: NONE

Notes:

Count (3)

Decision: n/a

FINANCE WORK NEEDED

Select Check Box for YES

Decision Type: NONE

Notes:

Initials of Approving Official (if required)

If more than 3 decisions, attach 2nd count sheet & mark this box





UNITED STATES PATENT AND TRADEMARK OFFICE

UNITED STATES DEPARTMENT OF COMMERCE
United States Patent and Trademark Office
Address: COMMISSIONER FOR PATENTS
P.O. Box 1450
Alexandria, Virginia 22313-1450
www.uspto.gov

Table with 7 columns: APPLICATION NUMBER, FILING or 371(c) DATE, GRP ART UNIT, FIL FEE REC'D, ATTY. DOCKET NO, TOT CLAIMS, IND CLAIMS. Row 1: 29/480,113, 01/23/2014, 2913, 190, A.HAZ-003, 1, 1

CONFIRMATION NO. 2342

FILING RECEIPT

59259
ITALIA IP
3500 WEST OLIVE AVE.
SUITE 300
BURBANK, CA 91505



Date Mailed: 01/29/2014

Receipt is acknowledged of this non-provisional patent application. The application will be taken up for examination in due course. Applicant will be notified as to the results of the examination. Any correspondence concerning the application must include the following identification information: the U.S. APPLICATION NUMBER, FILING DATE, NAME OF APPLICANT, and TITLE OF INVENTION. Fees transmitted by check or draft are subject to collection. Please verify the accuracy of the data presented on this receipt. If an error is noted on this Filing Receipt, please submit a written request for a Filing Receipt Correction. Please provide a copy of this Filing Receipt with the changes noted thereon. If you received a "Notice to File Missing Parts" for this application, please submit any corrections to this Filing Receipt with your reply to the Notice. When the USPTO processes the reply to the Notice, the USPTO will generate another Filing Receipt incorporating the requested corrections

Inventor(s) Archie Hazel, Jonesboro, IL;

Applicant(s) Archie Hazel, Jonesboro, IL;

Power of Attorney: The patent practitioners associated with Customer Number 59259

Domestic Applications for which benefit is claimed - None.

A proper domestic benefit claim must be provided in an Application Data Sheet in order to constitute a claim for domestic benefit. See 37 CFR 1.76 and 1.78.

Foreign Applications for which priority is claimed (You may be eligible to benefit from the Patent Prosecution Highway program at the USPTO. Please see http://www.uspto.gov for more information.) - None.

Foreign application information must be provided in an Application Data Sheet in order to constitute a claim to foreign priority. See 37 CFR 1.55 and 1.76.

If Required, Foreign Filing License Granted: 01/28/2014

The country code and number of your priority application, to be used for filing abroad under the Paris Convention, is US 29/480,113

Projected Publication Date: None, application is not eligible for pre-grant publication

Non-Publication Request: No

Early Publication Request: No

** MICRO ENTITY **

Title

HUMMINGBIRD FEEDER PARTITION

Preliminary Class

D30

Statement under 37 CFR 1.55 or 1.78 for AIA (First Inventor to File) Transition Applications: No**PROTECTING YOUR INVENTION OUTSIDE THE UNITED STATES**

Since the rights granted by a U.S. patent extend only throughout the territory of the United States and have no effect in a foreign country, an inventor who wishes patent protection in another country must apply for a patent in a specific country or in regional patent offices. Applicants may wish to consider the filing of an international application under the Patent Cooperation Treaty (PCT). An international (PCT) application generally has the same effect as a regular national patent application in each PCT-member country. The PCT process **simplifies** the filing of patent applications on the same invention in member countries, but **does not result** in a grant of "an international patent" and does not eliminate the need of applicants to file additional documents and fees in countries where patent protection is desired.

Almost every country has its own patent law, and a person desiring a patent in a particular country must make an application for patent in that country in accordance with its particular laws. Since the laws of many countries differ in various respects from the patent law of the United States, applicants are advised to seek guidance from specific foreign countries to ensure that patent rights are not lost prematurely.

Applicants also are advised that in the case of inventions made in the United States, the Director of the USPTO must issue a license before applicants can apply for a patent in a foreign country. The filing of a U.S. patent application serves as a request for a foreign filing license. The application's filing receipt contains further information and guidance as to the status of applicant's license for foreign filing.

Applicants may wish to consult the USPTO booklet, "General Information Concerning Patents" (specifically, the section entitled "Treaties and Foreign Patents") for more information on timeframes and deadlines for filing foreign patent applications. The guide is available either by contacting the USPTO Contact Center at 800-786-9199, or it can be viewed on the USPTO website at <http://www.uspto.gov/web/offices/pac/doc/general/index.html>.

For information on preventing theft of your intellectual property (patents, trademarks and copyrights), you may wish to consult the U.S. Government website, <http://www.stopfakes.gov>. Part of a Department of Commerce initiative, this website includes self-help "toolkits" giving innovators guidance on how to protect intellectual property in specific countries such as China, Korea and Mexico. For questions regarding patent enforcement issues, applicants may call the U.S. Government hotline at 1-866-999-HALT (1-866-999-4258).

LICENSE FOR FOREIGN FILING UNDER
Title 35, United States Code, Section 184
Title 37, Code of Federal Regulations, 5.11 & 5.15

GRANTED

The applicant has been granted a license under 35 U.S.C. 184, if the phrase "IF REQUIRED, FOREIGN FILING LICENSE GRANTED" followed by a date appears on this form. Such licenses are issued in all applications where the conditions for issuance of a license have been met, regardless of whether or not a license may be required as set forth in 37 CFR 5.15. The scope and limitations of this license are set forth in 37 CFR 5.15(a) unless an earlier license has been issued under 37 CFR 5.15(b). The license is subject to revocation upon written notification. The date indicated is the effective date of the license, unless an earlier license of similar scope has been granted under 37 CFR 5.13 or 5.14.

This license is to be retained by the licensee and may be used at any time on or after the effective date thereof unless it is revoked. This license is automatically transferred to any related applications(s) filed under 37 CFR 1.53(d). This license is not retroactive.

The grant of a license does not in any way lessen the responsibility of a licensee for the security of the subject matter as imposed by any Government contract or the provisions of existing laws relating to espionage and the national security or the export of technical data. Licensees should apprise themselves of current regulations especially with respect to certain countries, of other agencies, particularly the Office of Defense Trade Controls, Department of State (with respect to Arms, Munitions and Implements of War (22 CFR 121-128)); the Bureau of Industry and Security, Department of Commerce (15 CFR parts 730-774); the Office of Foreign Assets Control, Department of Treasury (31 CFR Parts 500+) and the Department of Energy.

NOT GRANTED

No license under 35 U.S.C. 184 has been granted at this time, if the phrase "IF REQUIRED, FOREIGN FILING LICENSE GRANTED" DOES NOT appear on this form. Applicant may still petition for a license under 37 CFR 5.12, if a license is desired before the expiration of 6 months from the filing date of the application. If 6 months has lapsed from the filing date of this application and the licensee has not received any indication of a secrecy order under 35 U.S.C. 181, the licensee may foreign file the application pursuant to 37 CFR 5.15(b).

SelectUSA

The United States represents the largest, most dynamic marketplace in the world and is an unparalleled location for business investment, innovation, and commercialization of new technologies. The U.S. offers tremendous resources and advantages for those who invest and manufacture goods here. Through SelectUSA, our nation works to promote and facilitate business investment. SelectUSA provides information assistance to the international investor community; serves as an ombudsman for existing and potential investors; advocates on behalf of U.S. cities, states, and regions competing for global investment; and counsels U.S. economic development organizations on investment attraction best practices. To learn more about why the United States is the best country in the world to develop technology, manufacture products, deliver services, and grow your business, visit <http://www.SelectUSA.gov> or call +1-202-482-6800.



UNITED STATES PATENT AND TRADEMARK OFFICE

UNITED STATES DEPARTMENT OF COMMERCE
United States Patent and Trademark Office
Address: COMMISSIONER FOR PATENTS
P.O. Box 1450
Alexandria, Virginia 22313-1450
www.uspto.gov

APPLICATION NUMBER	FILING OR 371(C) DATE	FIRST NAMED APPLICANT	ATTY. DOCKET NO./TITLE
29/480,113	01/23/2014	Archie Hazel	A.HAZ-003

CONFIRMATION NO. 2342

POA ACCEPTANCE LETTER



59259
ITALIA IP
3500 WEST OLIVE AVE.
SUITE 300
BURBANK, CA 91505

Date Mailed: 01/29/2014

NOTICE OF ACCEPTANCE OF POWER OF ATTORNEY

This is in response to the Power of Attorney filed 01/23/2014.

The Power of Attorney in this application is accepted. Correspondence in this application will be mailed to the above address as provided by 37 CFR 1.33.

/khoang/

Office of Data Management, Application Assistance Unit (571) 272-4000, or (571) 272-4200, or 1-888-786-0101

Under the Paperwork Reduction Act of 1995, no persons are required to respond to a collection of information unless it displays a valid OMB control number.

TRANSMITTAL FOR POWER OF ATTORNEY TO ONE OR MORE REGISTERED PRACTITIONERS

NOTE: This form is to be submitted with the Power of Attorney by Applicant form (PTO/AIA/82B or equivalent) to identify the application to which the Power of Attorney is directed, in accordance with 37 CFR 1.5. If the Power of Attorney by Applicant form is not accompanied by this transmittal form or an equivalent, the Power of Attorney will not be recognized in the application.

Application Number	
Filing Date	
First Named Inventor	Archie Hazel
Title	Hummingbird Feeder Partition
Art Unit	
Examiner Name	
Attorney Docket Number	A.HAZ-003

SIGNATURE of Applicant or Patent Practitioner

Signature	/James A. Italia/	Date	January 22, 2014
Name	James A. Italia	Telephone	818-973-2720
Registration Number	56,549		

NOTE: This form must be signed in accordance with 37 CFR 1.33. See 37 CFR 1.4(d) for signature requirements and certifications.

*Total of 1 forms are submitted.

This collection of information is required by 37 CFR 1.31, 1.32 and 1.33. The information is required to obtain or retain a benefit by the public which is to file (and by the USPTO to process) an application. Confidentiality is governed by 35 U.S.C. 122 and 37 CFR 1.11 and 1.14. This collection is estimated to take 3 minutes to complete, including gathering, preparing, and submitting the completed application form to the USPTO. Time will vary depending upon the individual case. Any comments on the amount of time you require to complete this form and/or suggestions for reducing this burden, should be sent to the Chief Information Officer, U.S. Patent and Trademark Office, U.S. Department of Commerce, P.O. Box 1450, Alexandria, VA 22313-1450. DO NOT SEND FEES OR COMPLETED FORMS TO THIS ADDRESS. **SEND TO: Commissioner for Patents, P.O. Box 1450, Alexandria, VA 22313-1450.**

If you need assistance in completing the form, call 1-800-PTO-9199 and select option 2.

POWER OF ATTORNEY BY APPLICANT

I hereby revoke all previous powers of attorney given in the application identified in the attached transmittal letter.

I hereby appoint Practitioner(s) associated with the following Customer Number as my/our attorney(s) or agent(s), and to transact all business in the United States Patent and Trademark Office connected therewith for the application referenced in the attached transmittal letter (form PTO/AIA/82A or equivalent):

59259

OR

I hereby appoint Practitioner(s) named below as my/our attorney(s) or agent(s), and to transact all business in the United States Patent and Trademark Office connected therewith for the application referenced in the attached transmittal letter (form PTO/AIA/82A or equivalent):

Name	Registration Number	Name	Registration Number

Please recognize or change the correspondence address for the application identified in the attached transmittal letter to:

The address associated with the above-mentioned Customer Number.

OR

The address associated with Customer Number:

OR

<input type="checkbox"/> Firm or Individual Name			
Address			
City	State	Zip	
Country			
Telephone	Email		

I am the Applicant:

Inventor or Joint Inventor

Legal Representative of a Deceased or Legally Incapacitated Inventor

Assignee or Person to Whom the Inventor is Under an Obligation to Assign

Person Who Otherwise Shows Sufficient Proprietary Interest (e.g., a petition under 37 CFR 1.46(b)(2) was granted in the application or is concurrently being filed with this document)

SIGNATURE of Applicant for Patent

Signature	/Archie Hazel/	Date	January 22, 2014
Name	Archie Hazel	Telephone	818-973-2720
Title and Company	Applicant/Inventor		

NOTE: Signature - This form must be signed by the applicant in accordance with 37 CFR 1.33. See 37 CFR 1.4 for signature requirements and certifications. Submit multiple forms for more than one signature, see below *.

*Total of 1 forms are submitted.

This collection of information is required by 37 CFR 1.31, 1.32 and 1.33. The information is required to obtain or retain a benefit by the public which is to file (and by the USPTO to process) an application. Confidentiality is governed by 35 U.S.C. 122 and 37 CFR 1.11 and 1.14. This collection is estimated to take 3 minutes to complete, including gathering, preparing, and submitting the completed application form to the USPTO. Time will vary depending upon the individual case. Any comments on the amount of time you require to complete this form and/or suggestions for reducing this burden, should be sent to the Chief Information Officer, U.S. Patent and Trademark Office, U.S. Department of Commerce, P.O. Box 1450, Alexandria, VA 22313-1450. DO NOT SEND FEES OR COMPLETED FORMS TO THIS ADDRESS. SEND TO: **Commissioner for Patents, P.O. Box 1450, Alexandria, VA 22313-1450.**

If you need assistance in completing the form, call 1-800-PTO-9199 and select option 2.

Privacy Act Statement

The **Privacy Act of 1974 (P.L. 93-579)** requires that you be given certain information in connection with your submission of the attached form related to a patent application or patent. Accordingly, pursuant to the requirements of the Act, please be advised that: (1) the general authority for the collection of this information is 35 U.S.C. 2(b)(2); (2) furnishing of the information solicited is voluntary; and (3) the principal purpose for which the information is used by the U.S. Patent and Trademark Office is to process and/or examine your submission related to a patent application or patent. If you do not furnish the requested information, the U.S. Patent and Trademark Office may not be able to process and/or examine your submission, which may result in termination of proceedings or abandonment of the application or expiration of the patent.

The information provided by you in this form will be subject to the following routine uses:

1. The information on this form will be treated confidentially to the extent allowed under the Freedom of Information Act (5 U.S.C. 552) and the Privacy Act (5 U.S.C. 552a). Records from this system of records may be disclosed to the Department of Justice to determine whether disclosure of these records is required by the Freedom of Information Act.
2. A record from this system of records may be disclosed, as a routine use, in the course of presenting evidence to a court, magistrate, or administrative tribunal, including disclosures to opposing counsel in the course of settlement negotiations.
3. A record in this system of records may be disclosed, as a routine use, to a Member of Congress submitting a request involving an individual, to whom the record pertains, when the individual has requested assistance from the Member with respect to the subject matter of the record.
4. A record in this system of records may be disclosed, as a routine use, to a contractor of the Agency having need for the information in order to perform a contract. Recipients of information shall be required to comply with the requirements of the Privacy Act of 1974, as amended, pursuant to 5 U.S.C. 552a(m).
5. A record related to an International Application filed under the Patent Cooperation Treaty in this system of records may be disclosed, as a routine use, to the International Bureau of the World Intellectual Property Organization, pursuant to the Patent Cooperation Treaty.
6. A record in this system of records may be disclosed, as a routine use, to another federal agency for purposes of National Security review (35 U.S.C. 181) and for review pursuant to the Atomic Energy Act (42 U.S.C. 218(c)).
7. A record from this system of records may be disclosed, as a routine use, to the Administrator, General Services, or his/her designee, during an inspection of records conducted by GSA as part of that agency's responsibility to recommend improvements in records management practices and programs, under authority of 44 U.S.C. 2904 and 2906. Such disclosure shall be made in accordance with the GSA regulations governing inspection of records for this purpose, and any other relevant (*i.e.*, GSA or Commerce) directive. Such disclosure shall not be used to make determinations about individuals.
8. A record from this system of records may be disclosed, as a routine use, to the public after either publication of the application pursuant to 35 U.S.C. 122(b) or issuance of a patent pursuant to 35 U.S.C. 151. Further, a record may be disclosed, subject to the limitations of 37 CFR 1.14, as a routine use, to the public if the record was filed in an application which became abandoned or in which the proceedings were terminated and which application is referenced by either a published application, an application open to public inspection or an issued patent.
9. A record from this system of records may be disclosed, as a routine use, to a Federal, State, or local law enforcement agency, if the USPTO becomes aware of a violation or potential violation of law or regulation.

**CERTIFICATION OF MICRO ENTITY STATUS
 (GROSS INCOME BASIS)**

Application Number or Control Number (if applicable):	Patent Number (if applicable):
First Named Inventor: Archie Hazel	Title of Invention: Hummingbird Feeder Partition

The applicant hereby certifies the following—

- (1) **SMALL ENTITY REQUIREMENT** - The applicant qualifies as a small entity as defined in 37 CFR 1.27.
- (2) **APPLICATION FILING LIMIT** - Neither the applicant nor the inventor nor a joint inventor has been named as the inventor or a joint inventor on more than four previously filed U.S. patent applications, excluding provisional applications and international applications under the Patent Cooperation Treaty (PCT) for which the basic national fee under 37 CFR 1.492(a) was not paid, and also excluding patent applications for which the applicant has assigned all ownership rights or is obligated to assign all ownership rights as a result of the applicant's previous employment.
- (3) **GROSS INCOME LIMIT ON APPLICANTS AND INVENTORS** - Neither the applicant nor the inventor nor a joint inventor, in the calendar year preceding the calendar year in which the applicable fee is being paid, had a gross income, as defined in section 61(a) of the Internal Revenue Code of 1986 (26 U.S.C. 61(a)), exceeding the "Maximum Qualifying Gross Income" reported on the USPTO website at http://www.uspto.gov/patents/law/micro_entity.jsp which is equal to three times the median household income for that preceding calendar year, as most recently reported by the Bureau of the Census.
- (4) **GROSS INCOME LIMIT ON PARTIES WITH AN "OWNERSHIP INTEREST"** - Neither the applicant nor the inventor nor a joint inventor has assigned, granted, or conveyed, nor is under an obligation by contract or law to assign, grant, or convey, a license or other ownership interest in the application concerned to an entity that, in the calendar year preceding the calendar year in which the applicable fee is being paid, had a gross income, as defined in section 61(a) of the Internal Revenue Code of 1986, exceeding the "Maximum Qualifying Gross Income" reported on the USPTO website at http://www.uspto.gov/patents/law/micro_entity.jsp which is equal to three times the median household income for that preceding calendar year, as most recently reported by the Bureau of the Census.

SIGNATURE by a party set forth in 37 CFR 1.33(b)

Signature	/James A. Italia/				
Name	James A. Italia				
Date	January 22, 2014	Telephone	818-973-2720	Registration No.	56,549



There is more than one inventor and I am one of the inventors who are jointly identified as the applicant. Additional certification form(s) signed by the other joint inventor(s) are included with this form.

Privacy Act Statement

The **Privacy Act of 1974 (P.L. 93-579)** requires that you be given certain information in connection with your submission of the attached form related to a patent application or patent. Accordingly, pursuant to the requirements of the Act, please be advised that: (1) the general authority for the collection of this information is 35 U.S.C. 2(b)(2); (2) furnishing of the information solicited is voluntary; and (3) the principal purpose for which the information is used by the U.S. Patent and Trademark Office is to process and/or examine your submission related to a patent application or patent. If you do not furnish the requested information, the U.S. Patent and Trademark Office may not be able to process and/or examine your submission, which may result in termination of proceedings or abandonment of the application or expiration of the patent.

The information provided by you in this form will be subject to the following routine uses:

1. The information on this form will be treated confidentially to the extent allowed under the Freedom of Information Act (5 U.S.C. 552) and the Privacy Act (5 U.S.C. 552a). Records from this system of records may be disclosed to the Department of Justice to determine whether disclosure of these records is required by the Freedom of Information Act.
2. A record from this system of records may be disclosed, as a routine use, in the course of presenting evidence to a court, magistrate, or administrative tribunal, including disclosures to opposing counsel in the course of settlement negotiations.
3. A record in this system of records may be disclosed, as a routine use, to a Member of Congress submitting a request involving an individual, to whom the record pertains, when the individual has requested assistance from the Member with respect to the subject matter of the record.
4. A record in this system of records may be disclosed, as a routine use, to a contractor of the Agency having need for the information in order to perform a contract. Recipients of information shall be required to comply with the requirements of the Privacy Act of 1974, as amended, pursuant to 5 U.S.C. 552a(m).
5. A record related to an International Application filed under the Patent Cooperation Treaty in this system of records may be disclosed, as a routine use, to the International Bureau of the World Intellectual Property Organization, pursuant to the Patent Cooperation Treaty.
6. A record in this system of records may be disclosed, as a routine use, to another federal agency for purposes of National Security review (35 U.S.C. 181) and for review pursuant to the Atomic Energy Act (42 U.S.C. 218(c)).
7. A record from this system of records may be disclosed, as a routine use, to the Administrator, General Services, or his/her designee, during an inspection of records conducted by GSA as part of that agency's responsibility to recommend improvements in records management practices and programs, under authority of 44 U.S.C. 2904 and 2906. Such disclosure shall be made in accordance with the GSA regulations governing inspection of records for this purpose, and any other relevant (*i.e.*, GSA or Commerce) directive. Such disclosure shall not be used to make determinations about individuals.
8. A record from this system of records may be disclosed, as a routine use, to the public after either publication of the application pursuant to 35 U.S.C. 122(b) or issuance of a patent pursuant to 35 U.S.C. 151. Further, a record may be disclosed, subject to the limitations of 37 CFR 1.14, as a routine use, to the public if the record was filed in an application which became abandoned or in which the proceedings were terminated and which application is referenced by either a published application, an application open to public inspection or an issued patent.
9. A record from this system of records may be disclosed, as a routine use, to a Federal, State, or local law enforcement agency, if the USPTO becomes aware of a violation or potential violation of law or regulation.

Electronic Patent Application Fee Transmittal

Application Number:	
Filing Date:	
Title of Invention:	HUMMINGBIRD FEEDER PARTITION
First Named Inventor/Applicant Name:	Archie Hazel
Filer:	James Anthony Italia
Attorney Docket Number:	A.HAZ-003

Filed as Micro Entity

Design Filing Fees

Description	Fee Code	Quantity	Amount	Sub-Total in USD(\$)
Basic Filing:				
BASIC DSGN APPL. FILING FEE-MICRO-ENTITY	3012	1	45	45
Design Search Fee	3112	1	30	30
Design Examination Fee	3312	1	115	115

Pages:

Claims:

Miscellaneous-Filing:

Petition:

Patent-Appeals-and-Interference:

Description	Fee Code	Quantity	Amount	Sub-Total in USD(\$)
Post-Allowance-and-Post-Issuance:				
Extension-of-Time:				
Miscellaneous:				
Total in USD (\$)				190

Electronic Acknowledgement Receipt

EFS ID:	18003350
Application Number:	29480113
International Application Number:	
Confirmation Number:	2342
Title of Invention:	HUMMINGBIRD FEEDER PARTITION
First Named Inventor/Applicant Name:	Archie Hazel
Customer Number:	59259
Filer:	James Anthony Italia
Filer Authorized By:	
Attorney Docket Number:	A.HAZ-003
Receipt Date:	23-JAN-2014
Filing Date:	
Time Stamp:	14:14:20
Application Type:	Design

Payment information:

Submitted with Payment	yes
Payment Type	Credit Card
Payment was successfully received in RAM	\$190
RAM confirmation Number	462
Deposit Account	
Authorized User	

File Listing:

Document Number	Document Description	File Name	File Size(Bytes)/ Message Digest	Multi Part /.zip	Pages (if appl.)
-----------------	----------------------	-----------	----------------------------------	------------------	------------------

1	Specification	HummingbirdFeederDPA.pdf	11136 1fb4c5a4ba987242cf945a405ad64bc13d7c e667	no	1
Warnings:					
Information:					
2	Drawings-only black and white line drawings	Figs1Thru8.pdf	1017811 33c8b9d71bef1311a7d071c217d7314e656 1f775	no	5
Warnings:					
Information:					
3	Oath or Declaration filed	Declarationv1.pdf	188451 e7abcc5d8d5b6edc20d817da5bdefcb94b7 78caa	no	3
Warnings:					
Information:					
4	Power of Attorney	POAEDIT.pdf	197583 ce53ebd7d1f59e5e809adbc86b53697f1b9 0dcde	no	3
Warnings:					
Information:					
5	Certification of Micro Entity (Gross Income Basis)	Micro.pdf	131109 aa561e15733024cb4004fc6a8477f83030c3 6e9e	no	2
Warnings:					
Information:					
6	Fee Worksheet (SB06)	fee-info.pdf	32487 3295c5034a23534730291bb88ae32de763 b6c13b	no	2
Warnings:					
Information:					
Total Files Size (in bytes):			1578577		

This Acknowledgement Receipt evidences receipt on the noted date by the USPTO of the indicated documents, characterized by the applicant, and including page counts, where applicable. It serves as evidence of receipt similar to a Post Card, as described in MPEP 503.

New Applications Under 35 U.S.C. 111

If a new application is being filed and the application includes the necessary components for a filing date (see 37 CFR 1.53(b)-(d) and MPEP 506), a Filing Receipt (37 CFR 1.54) will be issued in due course and the date shown on this Acknowledgement Receipt will establish the filing date of the application.

National Stage of an International Application under 35 U.S.C. 371

If a timely submission to enter the national stage of an international application is compliant with the conditions of 35 U.S.C. 371 and other applicable requirements a Form PCT/DO/EO/903 indicating acceptance of the application as a national stage submission under 35 U.S.C. 371 will be issued in addition to the Filing Receipt, in due course.

New International Application Filed with the USPTO as a Receiving Office

If a new international application is being filed and the international application includes the necessary components for an international filing date (see PCT Article 11 and MPEP 1810), a Notification of the International Application Number and of the International Filing Date (Form PCT/RO/105) will be issued in due course, subject to prescriptions concerning national security, and the date shown on this Acknowledgement Receipt will establish the international filing date of the application.

IN THE UNITED STATES PATENT AND TRADEMARK OFFICE

A Design Patent Application for a:

HUMMINGBIRD FEEDER PARTITION

Invented by:

Archie Hazel

I, Archie Hazel, have invented a new design for a hummingbird feeder partition, as set forth in the following specification.

Figures

Fig. **1** is a perspective view of a hummingbird feeder partition showing my new design;

Fig. **2** is a front elevational view of the invention;

Fig. **3** is a rear elevational view of the invention;

Fig. **4** is a right-side elevational view of the invention;

Fig. **5** is a left-side elevational view of the invention;

Fig. **6** is a top plan view of the invention;

Fig. **7** is a bottom plan view of the invention; and

Fig. **8** is a perspective view of a single partition.

I claim:

The ornamental design for hummingbird feeder partition, as shown and described.

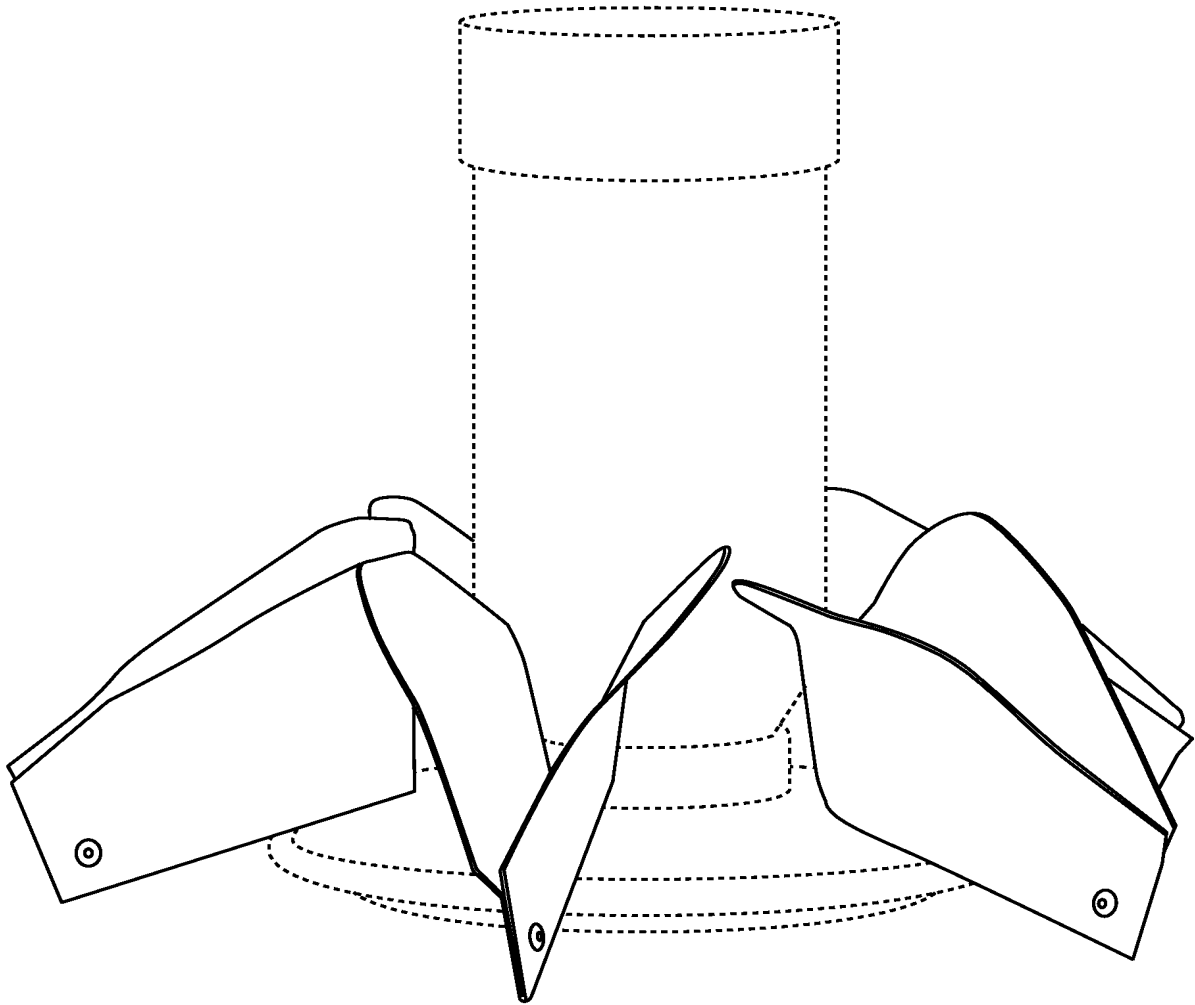

FIG. 1

FIG. 2

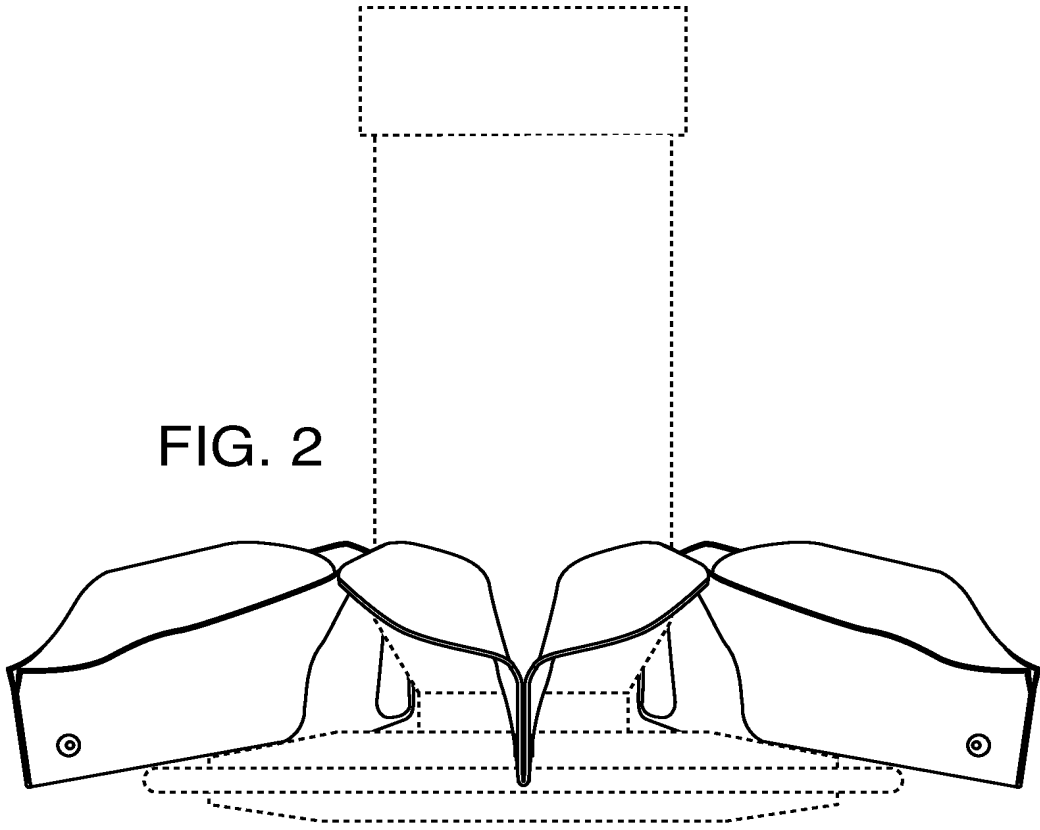
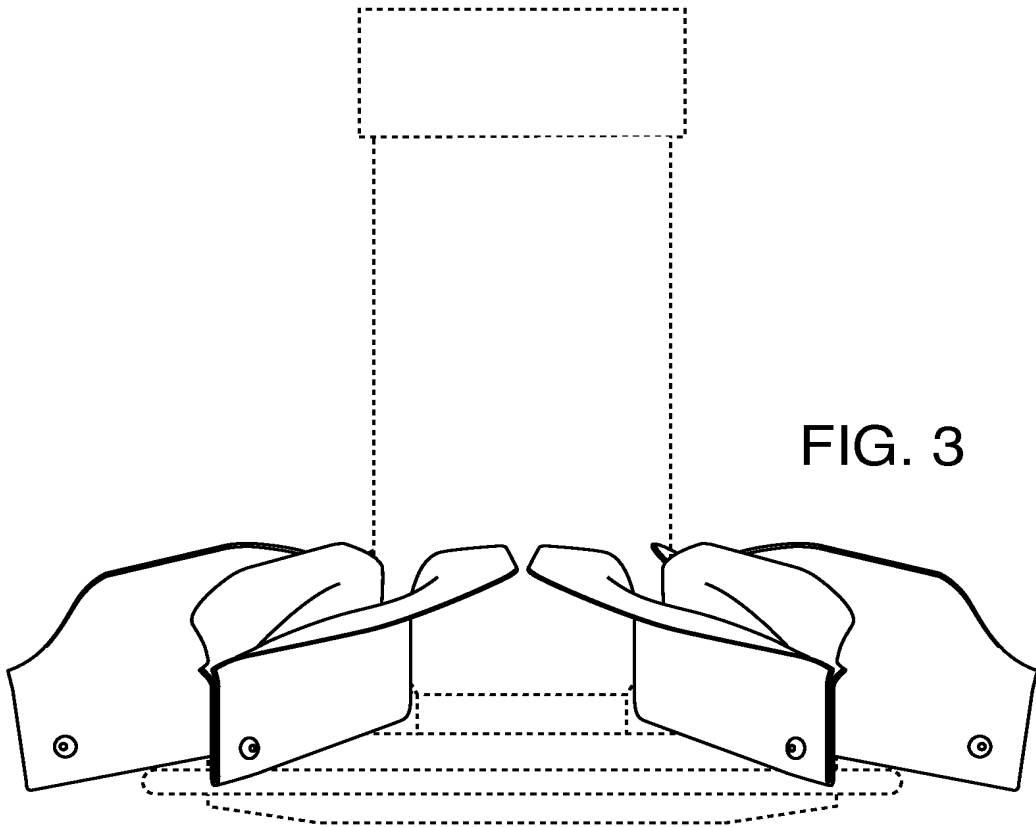

FIG. 3



3/5

FIG. 4

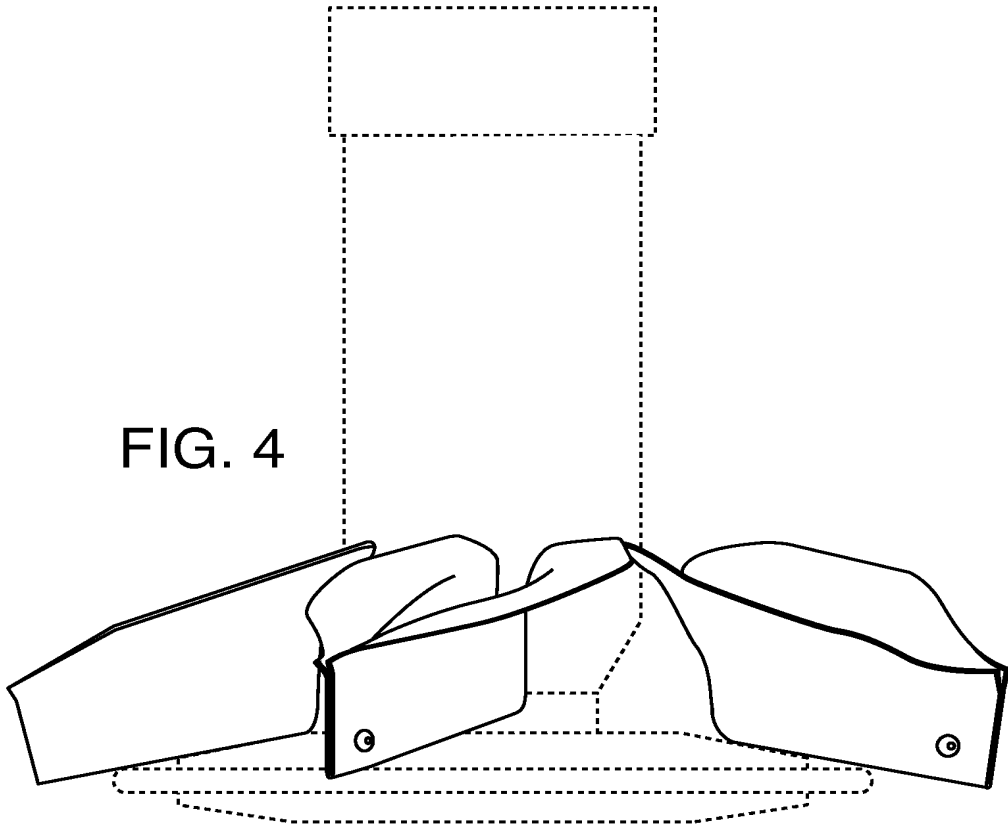
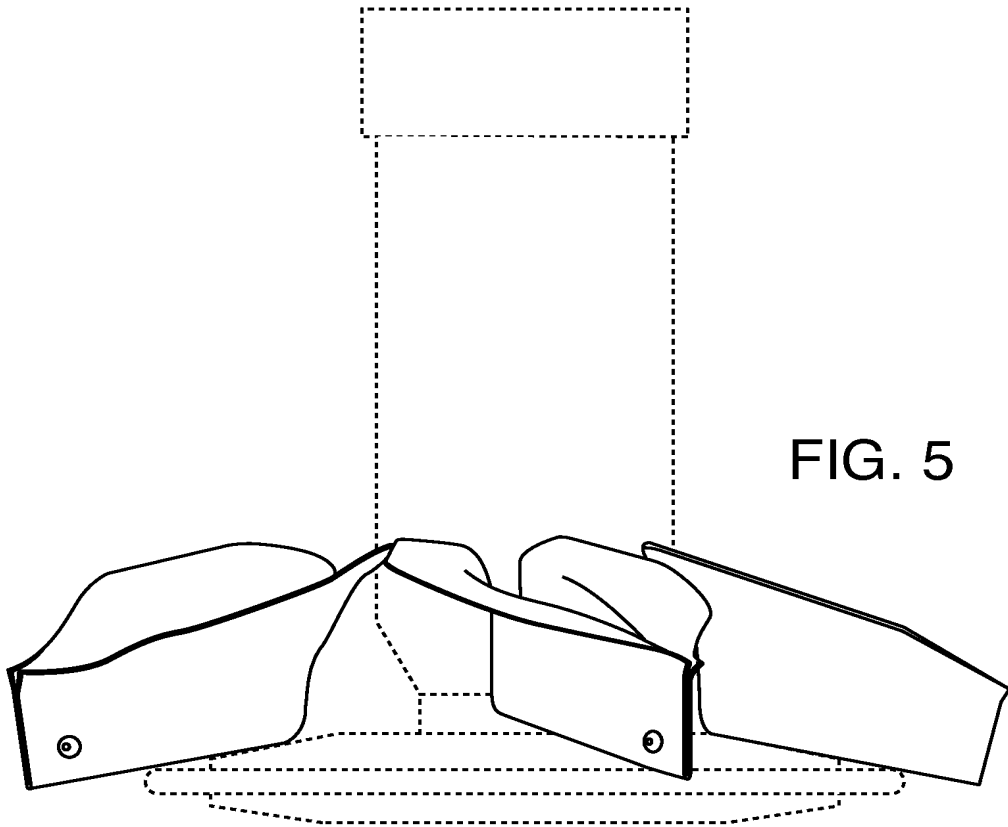

FIG. 5



4/5

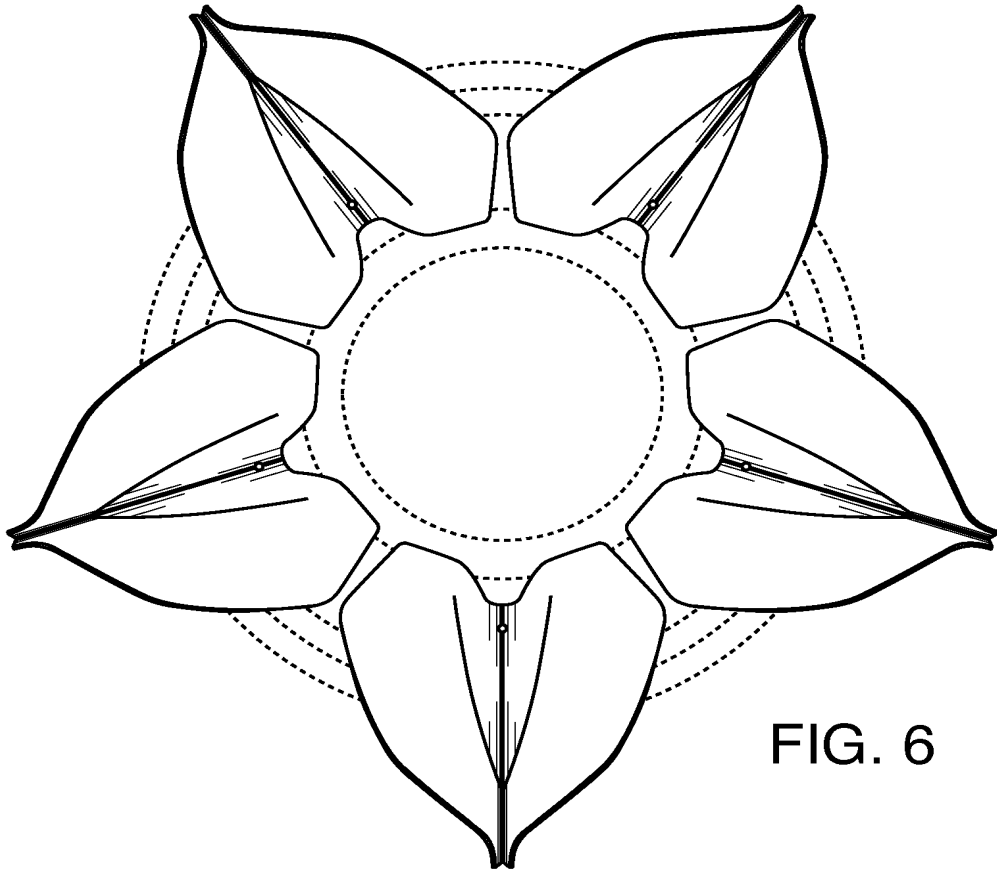

FIG. 6

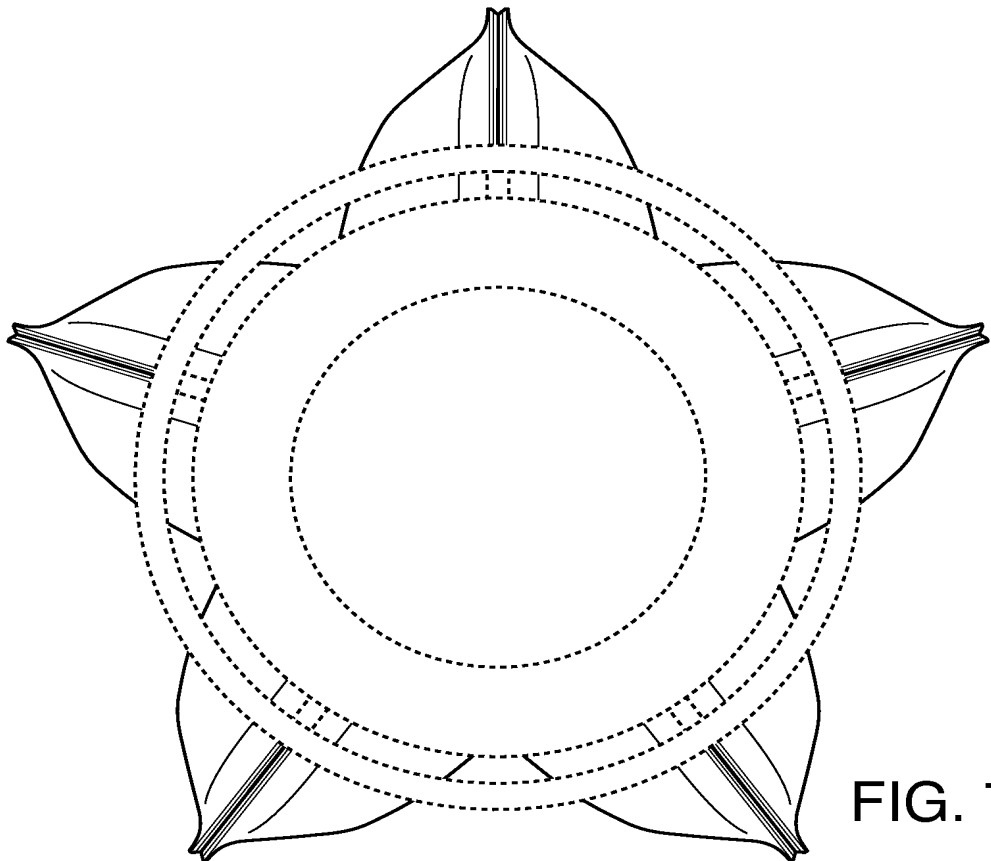

FIG. 7

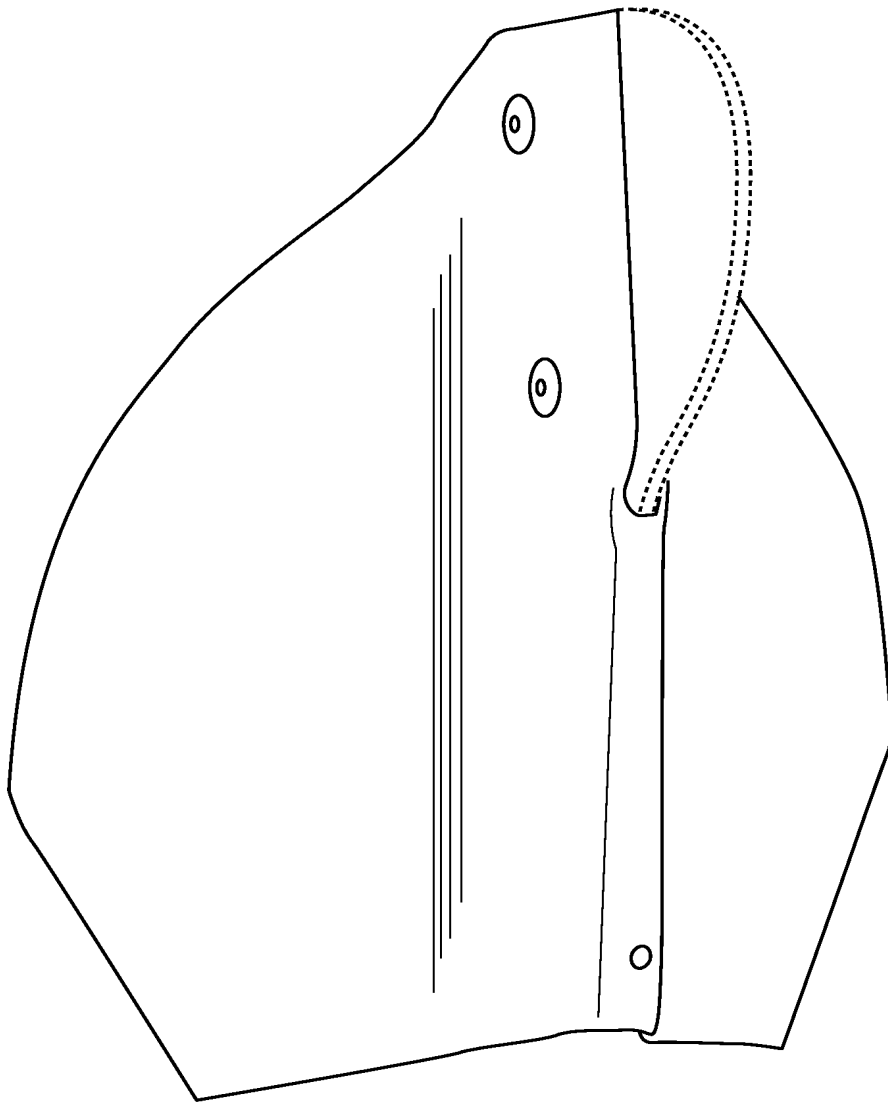

FIG. 8

<p>DECLARATION FOR UTILITY OR DESIGN PATENT APPLICATION (37 CFR 1.63)</p> <p> <input checked="" type="checkbox"/> Declaration Submitted With Initial Filing OR <input type="checkbox"/> Declaration Submitted After Initial Filing (surcharge (37 CFR 1.16(f)) required) </p>	Attorney Docket Number	A.HAZ-003
	First Named Inventor	Archie Hazel
	<i>COMPLETE IF KNOWN</i>	
	Application Number	
	Filing Date	
	Art Unit	
Examiner Name		

Hummingbird Feeder Partition

(Title of the Invention)

As a below named inventor, I hereby declare that:

This declaration is directed to:

The attached application,

OR

United States Application Number or PCT International application number _____ filed on _____.

The above-identified application was made or authorized to be made by me.

I believe I am the original inventor or an original joint inventor of a claimed invention in the application.

I hereby acknowledge that any willful false statement made in this declaration is punishable under 18 U.S.C. 1001 by fine or imprisonment of not more than five (5) years, or both.

Authorization To Permit Access To Application by Participating Office

If checked, the undersigned hereby grants the USPTO authority to provide the European Patent Office (EPO), the Japan Patent Office (JPO), the Korean Intellectual Property Office (KIPO), the World Intellectual Property Office (WIPO), and any other intellectual property offices in which a foreign application claiming priority to the above-identified patent application is filed access to the above-identified patent application. See 37 CFR 1.14(c) and (h). This box should not be checked if the applicant does not wish the EPO, JPO, KIPO, WIPO, or other intellectual property office in which a foreign application claiming priority to the above-identified patent application is filed to have access to the above-identified patent application.

In accordance with 37 CFR 1.14(h)(3), access will be provided to a copy of the above-identified patent application with respect to: 1) the above-identified patent application-as-filed; 2) any foreign application to which the above-identified patent application claims priority under 35 U.S.C. 119(a)-(d) if a copy of the foreign application that satisfies the certified copy requirement of 37 CFR 1.55 has been filed in the above-identified patent application; and 3) any U.S. application-as-filed from which benefit is sought in the above-identified patent application.

In accordance with 37 CFR 1.14(c), access may be provided to information concerning the date of filing the Authorization to Permit Access to Application by Participating Offices.

Under the Paperwork Reduction Act of 1995, no persons are required to respond to a collection of information unless it contains a valid OMB control number.

DECLARATION — Utility or Design Patent Application

Direct all correspondence to:	<input checked="" type="checkbox"/>	The address associated with Customer Number:	<input type="text" value="59259"/>	OR	<input type="checkbox"/>	Correspondence address below
Name						
Address						
City			State		Zip	
Country		Telephone		Email		
WARNING:						
<p>Petitioner/applicant is cautioned to avoid submitting personal information in documents filed in a patent application that may contribute to identity theft. Personal information such as social security numbers, bank account numbers, or credit card numbers (other than a check or credit card authorization form PTO-2038 submitted for payment purposes) is never required by the USPTO to support a petition or an application. If this type of personal information is included in documents submitted to the USPTO, petitioners/applicants should consider redacting such personal information from the documents before submitting them to the USPTO. Petitioner/applicant is advised that the record of a patent application is available to the public after publication of the application (unless a non-publication request in compliance with 37 CFR 1.213(a) is made in the application) or issuance of a patent. Furthermore, the record from an abandoned application may also be available to the public if the application is referenced in a published application or an issued patent (see 37 CFR 1.14). Checks and credit card authorization forms PTO-2038 submitted for payment purposes are not retained in the application file and therefore are not publicly available. Petitioner/applicant is advised that documents which form the record of a patent application (such as the PTO/SB/01) are placed into the Privacy Act system of records DEPARTMENT OF COMMERCE, COMMERCE-PAT-7, System name: <i>Patent Application Files</i>. Documents not retained in an application file (such as the PTO-2038) are placed into the Privacy Act system of COMMERCE/PAT-TM-10, System name: <i>Deposit Accounts and Electronic Funds Transfer Profiles</i>.</p>						
LEGAL NAME OF SOLE OR FIRST INVENTOR:						
(E.g., Given Name (first and middle (if any)) and Family Name or Surname)						
Archie Hazel						
Inventor's Signature				Date (Optional)		
/Archie Hazel/				January 22, 2014		
Residence: City		State		Country		
Jonesboro		IL		USA		
Mailing Address						
442 1/2 Cook Ave.						
City		State		Zip		Country
Jonesboro		IL		62952		USA
<input type="checkbox"/> Additional inventors are being named on the _____ supplemental sheet(s) PTO/AIA/10 attached hereto						

Privacy Act Statement

The Privacy Act of 1974 (P.L. 93-579) requires that you be given certain information in connection with your submission of the attached form related to a patent application or patent. Accordingly, pursuant to the requirements of the Act, please be advised that: (1) the general authority for the collection of this information is 35 U.S.C. 2(b)(2); (2) furnishing of the information solicited is voluntary; and (3) the principal purpose for which the information is used by the U.S. Patent and Trademark Office is to process and/or examine your submission related to a patent application or patent. If you do not furnish the requested information, the U.S. Patent and Trademark Office may not be able to process and/or examine your submission, which may result in termination of proceedings or abandonment of the application or expiration of the patent.

The information provided by you in this form will be subject to the following routine uses:

1. The information on this form will be treated confidentially to the extent allowed under the Freedom of Information Act (5 U.S.C. 552) and the Privacy Act (5 U.S.C. 552a). Records from this system of records may be disclosed to the Department of Justice to determine whether disclosure of these records is required by the Freedom of Information Act.
2. A record from this system of records may be disclosed, as a routine use, in the course of presenting evidence to a court, magistrate, or administrative tribunal, including disclosures to opposing counsel in the course of settlement negotiations.
3. A record in this system of records may be disclosed, as a routine use, to a Member of Congress submitting a request involving an individual, to whom the record pertains, when the individual has requested assistance from the Member with respect to the subject matter of the record.
4. A record in this system of records may be disclosed, as a routine use, to a contractor of the Agency having need for the information in order to perform a contract. Recipients of information shall be required to comply with the requirements of the Privacy Act of 1974, as amended, pursuant to 5 U.S.C. 552a(m).
5. A record related to an International Application filed under the Patent Cooperation Treaty in this system of records may be disclosed, as a routine use, to the International Bureau of the World Intellectual Property Organization, pursuant to the Patent Cooperation Treaty.
6. A record in this system of records may be disclosed, as a routine use, to another federal agency for purposes of National Security review (35 U.S.C. 181) and for review pursuant to the Atomic Energy Act (42 U.S.C. 218(c)).
7. A record from this system of records may be disclosed, as a routine use, to the Administrator, General Services, or his/her designee, during an inspection of records conducted by GSA as part of that agency's responsibility to recommend improvements in records management practices and programs, under authority of 44 U.S.C. 2904 and 2906. Such disclosure shall be made in accordance with the GSA regulations governing inspection of records for this purpose, and any other relevant (i.e., GSA or Commerce) directive. Such disclosure shall not be used to make determinations about individuals.
8. A record from this system of records may be disclosed, as a routine use, to the public after either publication of the application pursuant to 35 U.S.C. 122(b) or issuance of a patent pursuant to 35 U.S.C. 151. Further, a record may be disclosed, subject to the limitations of 37 CFR 1.14, as a routine use, to the public if the record was filed in an application which became abandoned or in which the proceedings were terminated and which application is referenced by either a published application, an application open to public inspection or an issued patent.
9. A record from this system of records may be disclosed, as a routine use, to a Federal, State, or local law enforcement agency, if the USPTO becomes aware of a violation or potential violation of law or regulation.

SCORE Placeholder Sheet for IFW Content

Application Number: 29480113

Document Date: 01/23/2014

The presence of this form in the IFW record indicates that the following document type was received in electronic format on the date identified above. This content is stored in the SCORE database.

Since this was an electronic submission, there is no physical artifact folder, no artifact folder is recorded in PALM, and no paper documents or physical media exist. The TIFF images in the IFW record were created from the original documents that are stored in SCORE.

- Drawing

At the time of document entry (noted above):

- USPTO employees may access SCORE content via eDAN using the Supplemental Content tab, or via the SCORE web page.
- External customers may access SCORE content via PAIR using the Supplemental Content tab.

**PETITION TO MAKE SPECIAL BASED ON AGE FOR ADVANCEMENT OF EXAMINATION
 UNDER 37 CFR 1.102(c)(1)**

Application Information

Application Number	29/480,113	Confirmation Number	2342	Filing Date	2014-01-23
Attorney Docket Number (optional)	A.HAZ-003	Art Unit		Examiner	
First Named Inventor	Archie Hazel				
Title of Invention	Hummingbird Feeder Partition				

Attention: Office of Petitions

An application may be made special for advancement of examination upon filing of a petition showing that the applicant is 65 years of age, or more. No fee is required with such a petition. See 37 CFR 1.102(c)(1) and MPEP 708.02 (IV).

APPLICANT HEREBY PETITIONS TO MAKE SPECIAL FOR ADVANCEMENT OF EXAMINATION IN THIS APPLICATION UNDER 37 CFR 1.102(c)(1) and MPEP 708.02 (IV) ON THE BASIS OF THE APPLICANT'S AGE.

A grantable petition requires one of the following items:

- (1) Statement by one named inventor in the application that he/she is 65 years of age, or more; or
- (2) Certification by a registered attorney/agent having evidence such as a birth certificate, passport, driver's license, etc. showing one named inventor in the application is 65 years of age, or more.

Name of Inventor who is 65 years of age, or older

Given Name	Middle Name	Family Name	Suffix
Archie		Hazel	

A signature of the applicant or representative is required in accordance with 37 CFR 1.33 and 10.18. Please see 37 CFR 1.4(d) for the format of the signature.

Select (1) or (2) :

- (1) I am an inventor in this application and I am 65 years of age, or more.
- (2) I am an attorney or agent registered to practice before the Patent and Trademark Office, and I certify that I am in possession of evidence, and will retain such in the application file record, showing that the inventor listed above is 65 years of age, or more.

Signature	/James A. Italia/	Date (YYYY-MM-DD)	2014-01-22
Name	James A. Italia	Registration Number	56549

Electronic Acknowledgement Receipt

EFS ID:	18003664
Application Number:	29480113
International Application Number:	
Confirmation Number:	2342
Title of Invention:	HUMMINGBIRD FEEDER PARTITION
First Named Inventor/Applicant Name:	Archie Hazel
Customer Number:	59259
Filer:	James Anthony Italia
Filer Authorized By:	
Attorney Docket Number:	A.HAZ-003
Receipt Date:	23-JAN-2014
Filing Date:	
Time Stamp:	14:26:41
Application Type:	Design

Payment information:

Submitted with Payment	no
------------------------	----

File Listing:

Document Number	Document Description	File Name	File Size(Bytes)/ Message Digest	Multi Part /.zip	Pages (if appl.)
1	Petition to make special based on Age/ Health	PetMakeSpecial1.pdf	61152 <small>c0e84acf16486e21e56cee9837e2d814f0018cfa</small>	no	1

Warnings:

Information:

This Acknowledgement Receipt evidences receipt on the noted date by the USPTO of the indicated documents, characterized by the applicant, and including page counts, where applicable. It serves as evidence of receipt similar to a Post Card, as described in MPEP 503.

New Applications Under 35 U.S.C. 111

If a new application is being filed and the application includes the necessary components for a filing date (see 37 CFR 1.53(b)-(d) and MPEP 506), a Filing Receipt (37 CFR 1.54) will be issued in due course and the date shown on this Acknowledgement Receipt will establish the filing date of the application.

National Stage of an International Application under 35 U.S.C. 371

If a timely submission to enter the national stage of an international application is compliant with the conditions of 35 U.S.C. 371 and other applicable requirements a Form PCT/DO/EO/903 indicating acceptance of the application as a national stage submission under 35 U.S.C. 371 will be issued in addition to the Filing Receipt, in due course.

New International Application Filed with the USPTO as a Receiving Office

If a new international application is being filed and the international application includes the necessary components for an international filing date (see PCT Article 11 and MPEP 1810), a Notification of the International Application Number and of the International Filing Date (Form PCT/RO/105) will be issued in due course, subject to prescriptions concerning national security, and the date shown on this Acknowledgement Receipt will establish the international filing date of the application.